

**S,W and SpaceSaver®**  
**S Centrifugal Pumps**  
**W Centrifugal Pumps**  
**SpaceSaver® Centrifugal Pumps**



**NATIONAL OILWELL**  
**Mission Products Group**

[www.natoil.com](http://www.natoil.com)

# S&W PUMPS



## Proven Performance

S & W pumps have proven themselves in a broad range of industrial, processing and mining applications. This series of pumps is designed for your most demanding applications. These are heavy-duty, end-suction, single stage, vertically split, horizontal centrifugal pumps. They perform well handling corrosive fluids and slurries carrying abrasive suspended materials.

The SpaceSavers proven compact design is ideal for heavy-duty centrifugal pump applications that require minimal mounting space. The SpaceSaver handles solids well, easily passing materials up to 3/4" in diameter.

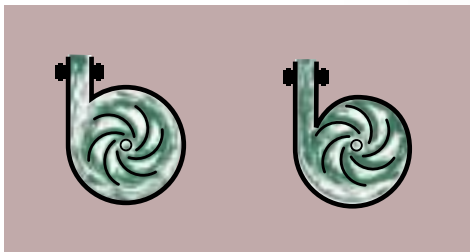

The unique design of these pumps centers the impeller in the casing. This reduces turbulence, cavitation and vibration. Life is greatly extended, especially in abrasive service.

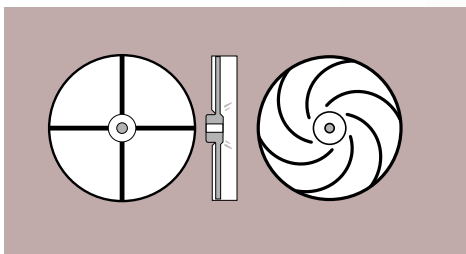

The semi-open, non-clogging impeller design is ideal for handling liquids containing suspended matter or solids. The back vanes reduce stuffing box pressures and extend packing life. Impellers are available in increments of 1/4 inch.

Fluid ends are available in a number of corrosion resistant alloys for the most severe service. Single units are available with capacities up to 1600 GPM and heads up to 360 feet. Complete units can be supplied with virtually any type of driver.

### Common S,W applications include:

- Various abrasive and corrosive slurries
- Salt water
- Hydrofluoric and sulfuric acids
- Caustic soda
- Black liquor
- Mining slurries
- Filter pump
- Filter backwash pump
- Transfer pump
- Supercharging pumps for reciprocating injection pumps

### Common SpaceSaver applications include:

- Back flush pump
- Multiplex liner cooling pump
- Clear liquid transfer pump

# Typical Configurations



## W

- 2 x 3 R & C
- 3 x 4 R & C
- 4 x 5 R & C
- 5 x 6 R & C
- 6 x 8 R

## S & SpaceSaver®

- 1 x 1½ C
- 1½ x 2 R & C
- 2 x 3 R 11 & C11
- 3 x 4 R 11

### Available sizes, configurations, and materials

Four casing sizes are available on the 1½" (S) pedestal. Five casing sizes are available on the 1¾" (W) pedestal. Choose either clockwise (R) or counter clockwise (C) rotation. (6 x 8 is available clockwise only and 1 x 1½ is available counter clockwise only.)

To change pump size you change only the impeller casing.

### Size designation examples

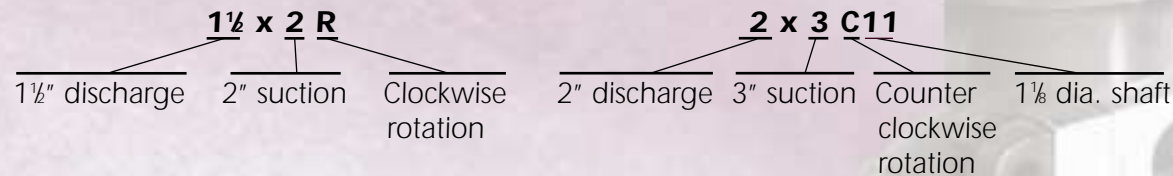

Shaft size is only indicated when ordering "S" Pumps (not for "W" Pump models).

Rotation is determined when viewed from the coupling end.

### How to order

When ordering specify per the following example:

Use the Head Capacity Range Charts on pages 10 through 15 To select the appropriate pump size.

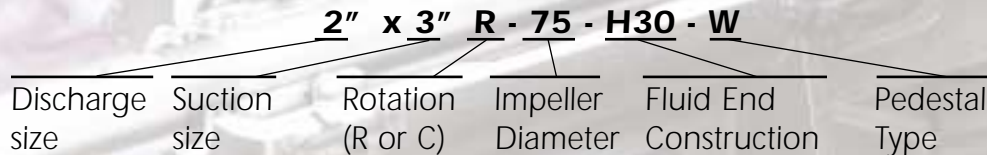

To indicate impeller diameter, determine the appropriate size in inches. Subtract 4 from the number of inches to create the first number of the impeller diameter code. For the second digit in the code indicate the number of "eighths" over the inch figure. For example, 11½ would be 75; 9½ would be 54; 4 would be 0.





# SpaceSaver parts list and materials

Item No.	Quantity	Part No.	Part Name
1	1	*	Casing
1A	8	11907-83	Stud
1B	8	3932-1	Nut
1C	1	10399-19-1	Gasket Casing
2	1	*	Impeller
3A	1	22781A	Key Assy., Imp
3B	1	3861-165	Cap Screw, Imp
3C	1	3936-22-EH	Seal, Imp Cap Screw
3D	1	3936-21-25	Washer, Imp
3E	1	22785A	Gasket Assy., Imp
4	1	22782A	Sleeve, Shaft
5	1	22780-01-01	Adapter
5A	4	3861-165	Cap Screw, Adapter
6	1	25014-01S-B§	Packing
7	1	8204-13A	Packing Gland
8	2	83701A	Gland Bolt Assy.
9	1	22871-1	Mechanical Seal-Carbon/Ceramic
9A	2	22871-2	Mechanical Seal-Tungsten/Tungsten
10	1	22784-12	Base
11	4	3861-165	Cap Screws, Mounting
12	1		Electric Motor

\*See material list. §Replaces P/N 8264-11S-OBA

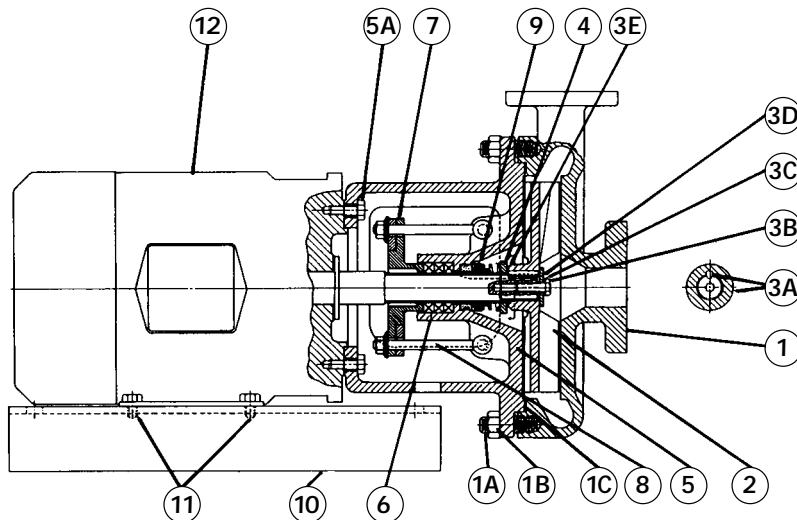

Material Code "XX"  
 -13 Aluminum Bronze  
 -01 Cast Iron  
 -04 316 Stainless Steel

See page 26 for materials analysis description.

## Casing Options

Pump Size	Part No.
1 x 1½ C	G3766-XX
1½ x 2 R	G4576-XX
1½ x 2 C	G4096-XX
2 X 3 R11	F4672-XX
2 X 3 C11	F4061-XX
3 X 4 R11	F5162-XX

## Impeller Options

Pump Size	Part No.
1 x 1½ C	4170-ZZ-XX
1½ x 2 C	4170-ZZ-XX
1½ x 2 R	4571-ZZ-XX
2 X 3 R11	4574-ZZ-XX
2 X 3 C11	4173-ZZ-XX
3 X 4 R11	5170-ZZ-XX

## Impeller Dia. Codes "ZZ"

Dash	Dia.	Dash	Dia.
-44	8½"	-24	6½"
-42	8¼"	-22	6¼"
-40	8"	-20	6"
-36	7¾"	-16	5¾"
-34	7½"	-14	5½"
-32	7¼"	-12	5¼"
-30	7"	-10	5"
-26	6¾"	-06	4¾"

## Example:

1 x 1½ C 8½" = 4170-44-01  
 1 x 1½ C 6¾" = 4170-44-01

## Part Number Coding

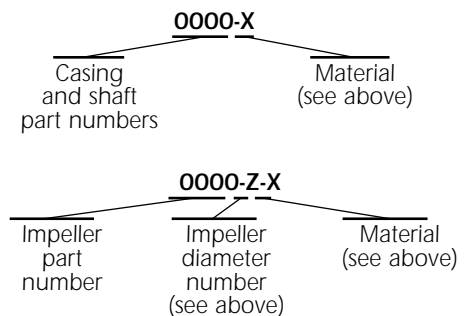

# SpaceSaver Centrifugal Pumps

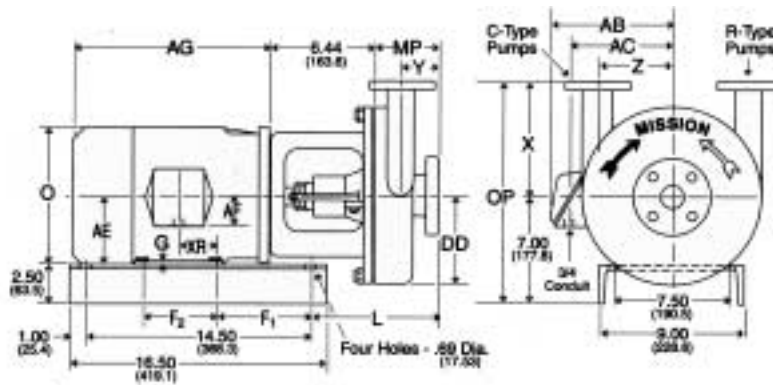

Pump Size	Discharge	Suction	OP	L	DD	MP	X	Y	Z	Weight Lbs.(Kg)
1 x 1½ C	1	1½	14.50 (368.3)	8.00 (203.2)	5.75 (146)	4.25 (108)	7.50 (190.5)	2.50 (63.5)	4.88 (124)	108 (48.98)
1½ x 2 R or C	1½	2	14.50 (368.3)	9.00 (228.6)	5.75 (146)	4.75 (120.7)	7.50 (190.5)	3.00 (76.2)	4.75 (120.6)	119 (53.97)
2 x 3 R or C	2	3	14.50 (368.3)	9.12 (231.6)	5.75 (146)	5.38 (136.7)	7.50 (190.5)	3.50 (88.9)	4.50 (114.3)	127 (57.6)
3 x 4 R	3	4	15.00 (381.0)	10.12 (257.0)	5.75 (146)	6.38 (162)	8.00 (203.2)	4.12 (104.7)	5.00 (127)	149 (67.57)

Motor Frame	AB	AC	AE	AF	AG	F1	F2	G	O	XR	Weight Lbs.(Kg)
182 TEFC	7.56 (192)	6.06 (153.9)	4.50 (114.3)	1.94 (49.3)	12.81 (325.4)	6.25 (158.8)	4.50 (114.3)	0.19 (4.8)	8.50 (215.9)	2.25 (57.2)	67 (30.4)
182 XPF	7.25 (184)	5.75 (146)	4.50 (114.3)	1.94 (49.3)	11.94 (303.3)	6.25 (158.8)	4.50 (114.3)	0.44 (11.2)	9.19 (233.4)	2.25 (57.2)	104 (47.2)
184 TEFC	7.56 (192)	6.06 (153.9)	4.50 (114.3)	1.94 (49.3)	13.81 (350.8)	6.25 (158.8)	5.50 (139.7)	0.19 (4.8)	8.50 (215.9)	2.75 (69.9)	79 (35.8)
184 XPF	7.25 (184)	5.75 (146)	4.50 (114.3)	1.94 (49.3)	12.94 (328.7)	6.25 (158.8)	5.50 (139.7)	0.44 (11.2)	9.19 (233.4)	2.75 (69.9)	120 (54.4)

Size	ID	Flange Dimensions* OD	BC	TK	No. of Holes	Size of Holes
1	1.00 (25.4)	4.25 (108)	3.12 (79.4)	0.56 (14.2)	4	0.62 (15.75)
1 1/2	1.50 (38.1)	5.00 (127)	3.88 (98.4)	0.69 (17.5)	4	0.62 (15.75)
2	2.00 (50.8)	6.00 (152.4)	4.75 (120.7)	0.75 (19.5)	4	0.62 (15.75)
3	3.00 (76.2)	7.50 (190.5)	6.00 (152.4)	0.94 (23.9)	4	0.62 (15.75)
4	4.00 (101.6)	9.00 (228.6)	7.50 (190.5)	0.94 (23.9)	4	0.62 (15.75)

Note: Motor frame dimensions are for Reliance electric motors. Other motors may vary.

\* ANSI Class 150 Steel Flange Dimensions.



## Type W 1<sup>7</sup>/<sub>8</sub>" Pump Parts List

Pump Size	Item 1 Casing	Item 2 Semi-Open Slip Fit Impeller	Item 3 Shaft§	Item 4 Wear Plate
2 x 3 R	G 4676-X	4610-Z-X		3779-X
2 x 3 C	G 3783-X	3781-Z-X		3779-X
3 x 4 R	F 4644-X	4605-Z-X	1. 3786-X	3779-X
3 x 4 C	F 3691-X	3689-Z-X	Slip Fit	3779-X
4 x 5 R	F 4732-X	4705-Z-X		3779-X
4 x 5 C	F 3800-X	3798-Z-X	2. 4932-21 Slip	3779-X
5 x 6 R	F 4742-X	4710-Z-X	Fit. All iron only	3779-X
5 x 6 C	F 4029-X	3903-Z-X		3779-X
6 x 8 R	F 5144-X	5142-Z-X		3779-X

1. Furnished with alloy pumps; will not fit 6 x 8.
2. Furnished with all cast iron pumps will not fit 6 x 8, has 1" longer shaft extension for belt drive.
3. Furnished with 6 x 8 pumps only.

Part Number	Part Name	Quan.	Item No.
11907-83	Stud-Casing	12	1A
3932-1	Nut-Casing Stud	12	1B
10399-20-1	Gasket-Casing	1	1C
*4372-3X	Key-Impeller End	1	3A
4372-521	Key-Coupling End	1	3B
**6209-8-X	Impeller Nuts	2	3C
3936-16-X	Washer-Impeller		3D
L3785	Pedestal	1	5
8262-6	Plug-Drip Pan Drain	2	5A
19368-01	Hydraulic Grease Fitting	5B	
25014-02W-B***	Packing Assembly		6
6480-2	Lantern Ring Half	2	6A
7406	Packing Gland Half	2	7
3701A	Gland Bolt Assembly	2	8
3932-8	Nut-Gland Bolt	2	8B
C3787	Water Slinger Assembly	1	9
3935-3	Set Screw	1	9A
7496-3	"O" Ring Water Slinger	1	9B
3790	Bearing Cap	2	10
3861-1	Bolt-Bearing Cap	4	10A
3932-2	Nut-Bearing Cap Bolt	4	10B
10399-23-1	Gasket-Bearing Cap	2	10C
3943-14	Grease Seal	2	10D
3944-3	Bearing	2	11
3861-2	Mounting Bolt	4	12A
23017	Name Plate	1	

\*6 x 8 pump uses Key Part No. 4372-7X.

\*\*This part is for slip fit shaft only.

\*\*\*Part No. for Chevron Packing: 8475-17W-1A.

\*\*\*Part No. for King Packing: 25015-02W-BA.

# Type S 1 1/8" Pump Parts List

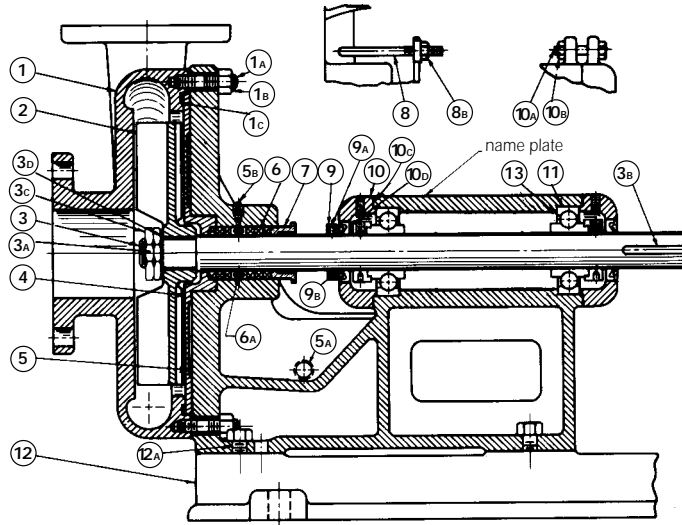

X: Denotes material of construction.  
(See page 5 Must be on purchase order.)

Z: Denotes impeller diameter.  
(See page 5 Must be on purchase order.)

§: Shaft is supplied with items  
3A, 3B and 3C as standard.

Note: Use "X" preceding shaft part number for  
chrome plate under gland packing area  
for abrasive service.

Pump Size	Item 1 Casing	Item 2 Semi-Open Slip Fit Impeller	Item 3 Shaft§	Item 4 Wear Plate
1 x 1 1/2 C	G 3766-X	4170-Z-X		3762-X
1 1/2 X 2 R	G 4576-X	4571-Z-X		3762-X
1 1/2 X 2 C	G 4096-X	4170-Z-X	3769-X	3762-X
2 x 3 R-11	G 4672-X	4574-Z-X	Slip Fit	3762-X
2 X 3 C-11	G 4061-X	4173-Z-X		3762-X
3 X 4 R-11	G 5162-X	5170-Z-X		3762-X

See page 26 for materials  
analysis description.

Part No.	Part Name	Quan.	Item No.
3862-1	Stud-Casing	8	1A
3932-1	Nut-Casing STUD	8	1B
10399-19-1	Gasket-Casing	1	1C
4372-1X	Key-Impeller End	1	3A
4372-221	Key-Coupling End	1	3B
6209-7X*	Impeller Nuts	2	3C
3936-2-X	Washer-Impeller	1	3D
E3768	Pedestal	1	5
8262-6	Plug-Drip Pan Drain	2	5A
19368-01	Hydraulic Grease Fitting	1	5B
25014-015-B**	Packing Assembly	1 Set	6
6480	Lantern Ring Half	2	6A
8204	Packing Gland Half	2	7

Part No.	Part Name	Quan.	Item No.
3701A	Gland Bolt Assembly	2	8
3932-8	Nut-Gland Bolt	2	8B
C3770	Water Slinger Assembly	1	9
3935-2	Set Screw	1	9A
7496-21	"O" Ring Water Slinger	1	9B
3773	Bearing Cap	2	10
3861-1	Bolt-Bearing Cap	4	10A
3932-2	Nut-Bearing Cap	4	10B
10399-21-1	Gasket-Bearing Cap	2	10C
3943-12	Grease Seal	2	10D
3944-1	Bearing	2	11
3861-2	Mounting Bolt	4	12A
23017	Name Plate	1	

\*This part is for slip fit shaft only.

\*\*Part No. for Chevron Packing Assembly: 8475-115-1A.

\*\*Part No. for King Packing Assembly: 25015-015-BA.



# Channel Base Dimensions

1 1/8 and 1 7/8 Pump Channel Bases for NEMA Motor Frames.

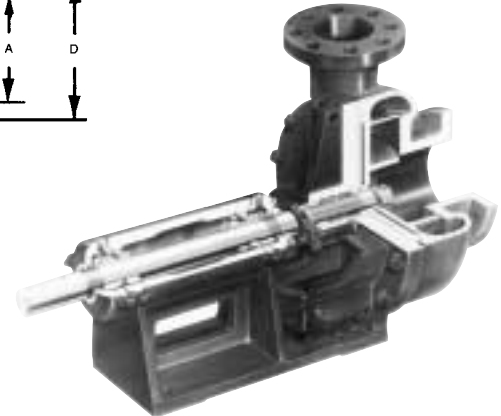
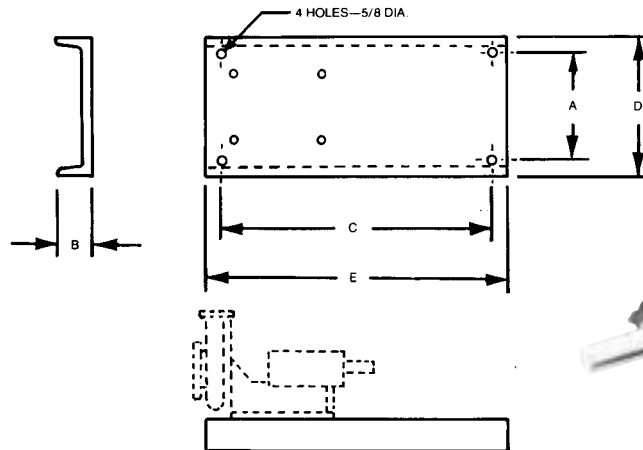

Pump Size	Motor Frame	Base No.	A	B	C	D	E
1 1/8	143T thru 215T	15901-1	9 1/4	3 1/16	38 5/8	12	41 5/8
1 1/8	254T thru 286TS	15901-2	15 1/8	3 15/16	44 7/8	18	47 7/8
1 7/8	143T thru 326TS	15901-3	15 1/8	3 15/16	51 1/2	18	54 7/16

Note: Pump mounting holes are drilled and tapped as required by pedestal size.

# Pedestal Casing Installation Dimensions

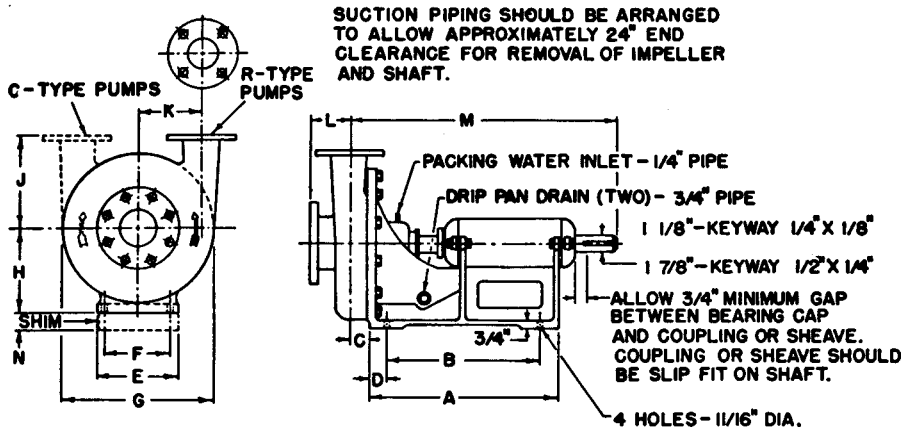

Pump Size	Pump Type (Shaft Dia.)	Discharge Pipe		Pipe Flanges**		Dimensions in inches													
		Size	Drilling	Size	Drilling	A	B	C	D	E	F	G	H	J	K	L	M		
1 x 1 1/2 - C	1 1/8	1	4 holes 5/8 dia.	3 1/8 B.C.	1 1/2	4 holes 5/8 dia.	3 7/8 B.C.	17	13	2	2	6 1/4	4 1/4	11 1/2	7	7 1/2	4 7/8	2 1/2	23 5/8
1 1/2 x 2 - R & C	1 1/8	1 1/2	4 holes 5/8 dia.	3 7/8 B.C.	2	4 holes 3/4 dia.	4 3/4 B.C.	17	13	2	2	6 1/4	4 1/4	11 1/2	7	7 1/2	4 3/4	3	23 5/8
2 x 3 - R11 & C11	1 1/8	2	4 holes 3/4 dia.	4 3/4 B.C.	3	4 holes 3/4 dia.	6 B.C.	17	13	2	2	6 1/4	4 1/4	11 1/2	7	7 1/2	4 1/2	3 1/2	23 5/8
3 x 4 - R11	1 7/8	3	4 holes 3/4 dia.	6 B.C.	4	4 holes 3/4 dia.	7 1/2 B.C.	17	13	2 1/2	2	6 1/4	4 1/4	12 3/4	7	8	5	4 1/8	24 1/4
2 x 3 - R & C	1 7/8	2	4 holes 3/4 dia.	4 3/4 B.C.	3	4 holes 3/4 dia.	6 B.C.	20 1/2	16 7/16	2	2	9	7	16 1/2	9	10 1/4	7	3 3/4	28 1/2
3 x 4 - R & C	1 7/8	3	4 holes 3/4 dia.	6 B.C.	4	4 holes 3/4 dia.	7 1/2 B.C.	20 1/2	16 7/16	2 1/8	2	9	7	16 1/2	9	10 1/4	6 3/4	4 1/4	28 5/8*
4 x 5 - R & C	1 7/8	4	8 holes 3/4 dia.	7 1/2 B.C.	5	4 holes 7/8 dia.	8 1/2 B.C.	20 1/2	16 7/16	2 3/4	2	9	7	16 1/2	9	11	6 1/8	5	29 1/4*
5 x 6 - R & C	1 7/8	5	8 holes 7/8 dia.	8 1/2 B.C.	6	4 holes 7/8 dia.	9 1/2 B.C.	20 1/2	16 7/16	3 1/8	2	9	7	16 1/2	9	11	6	5 3/4	29 5/8*
6 x 8 - R	1 7/8	6	8 holes 7/8 dia.	9 1/2 B.C.	8	4 holes 7/8 dia.	11 3/4 B.C.	20 1/2	16 7/16	4	2	9	7	22 1/2	9	14	8 3/8	6 1/4	31 1/2



## Fabricated Base Dimensions

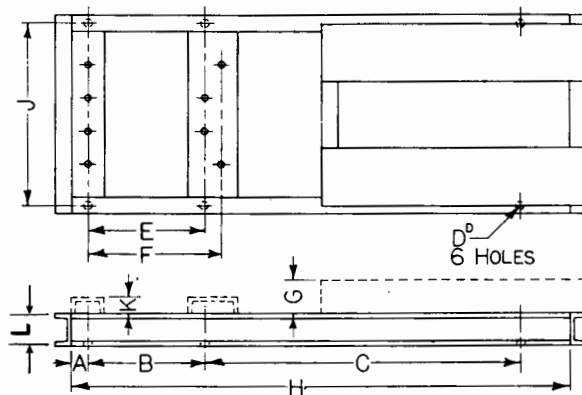

Pump bases designed to accommodate the following standard NEMA Motor Frame sizes

Base Size	Dimensions in inches +- 1/8 inches										
	A	B	C	D	E	F	G	H	J	K	L
FB-1	2	13	22	5/8	13	16 <sup>7</sup> / <sub>16</sub>	1 <sup>3</sup> / <sub>4</sub>	42 <sup>3</sup> / <sub>4</sub>	12 <sup>1</sup> / <sub>2</sub>	0	4
FB-2	2	20	21	7/8	13	16 <sup>7</sup> / <sub>16</sub>	0	52 <sup>3</sup> / <sub>8</sub>	19	0	6
FB-3	4	22	25	7/8	13	16 <sup>7</sup> / <sub>16</sub>	0	60 <sup>1</sup> / <sub>2</sub>	25	2	6
FB-4	4	24	30	7/8	13	16 <sup>7</sup> / <sub>16</sub>	0	66 <sup>1</sup> / <sub>8</sub>	27 <sup>3</sup> / <sub>8</sub>	2 <sup>1</sup> / <sub>2</sub>	6

Base Size	NEMA Frame for	
	"S" Type Pumps (1 <sup>1</sup> / <sub>8</sub> ")	"W" Type Pumps (1 <sup>7</sup> / <sub>8</sub> ")
FB-1	182T thru 215T	182T thru 215T
FB-2	254T thru 365TS	254T thru 326TS
FB-3	404T thru 445TS	364T thru 405TS
FB-4		444T thru 445TS

## Fabricated Steel Skid Dimensions

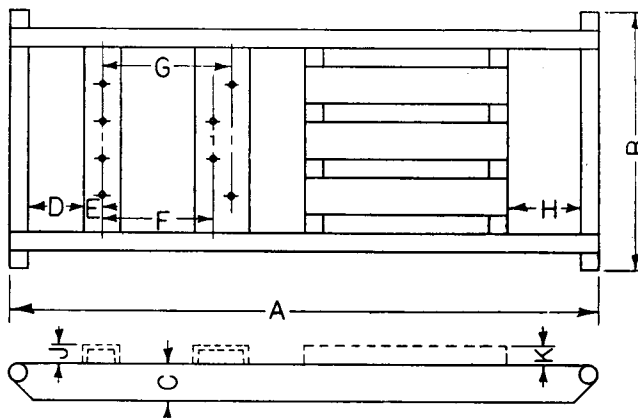

Pump bases designed to accommodate the following standard NEMA Motor Frame sizes

Base Size	Dimensions in inches +- 1/8 inches									
	A	B	C	D	E	F	G	H	J	K
FSB-1	66 <sup>1</sup> / <sub>2</sub>	25	4	14	2	13	16 <sup>7</sup> / <sub>16</sub>	4 <sup>5</sup> / <sub>8</sub>	0	1 <sup>3</sup> / <sub>4</sub>
FSB-2	77 <sup>7</sup> / <sub>16</sub>	34	6	14	2	13	16 <sup>7</sup> / <sub>16</sub>	7 <sup>1</sup> / <sub>4</sub>	0	0
FSB-3	88 <sup>11</sup> / <sub>16</sub>	45	6	14	2	13	16 <sup>7</sup> / <sub>16</sub>	8 <sup>5</sup> / <sub>8</sub>	2	0
FSB-4	96 <sup>3</sup> / <sub>16</sub>	48	6	14	2	13	16 <sup>7</sup> / <sub>16</sub>	12 <sup>1</sup> / <sub>4</sub>	2 <sup>1</sup> / <sub>2</sub>	0

Base Size	NEMA Frame for	
	"S" Type Pumps (1 <sup>1</sup> / <sub>8</sub> ")	"W" Type Pumps (1 <sup>7</sup> / <sub>8</sub> ")
FSB-1	182T thru 215T	182T thru 215T
FSB-2	254T thru 365TS	254T thru 365TS
FSB-3	404T thru 445TS	404T thru 405TS
FSB-4		444T thru 445TS

1 x 1½ C 1150 RPM S Pedestal

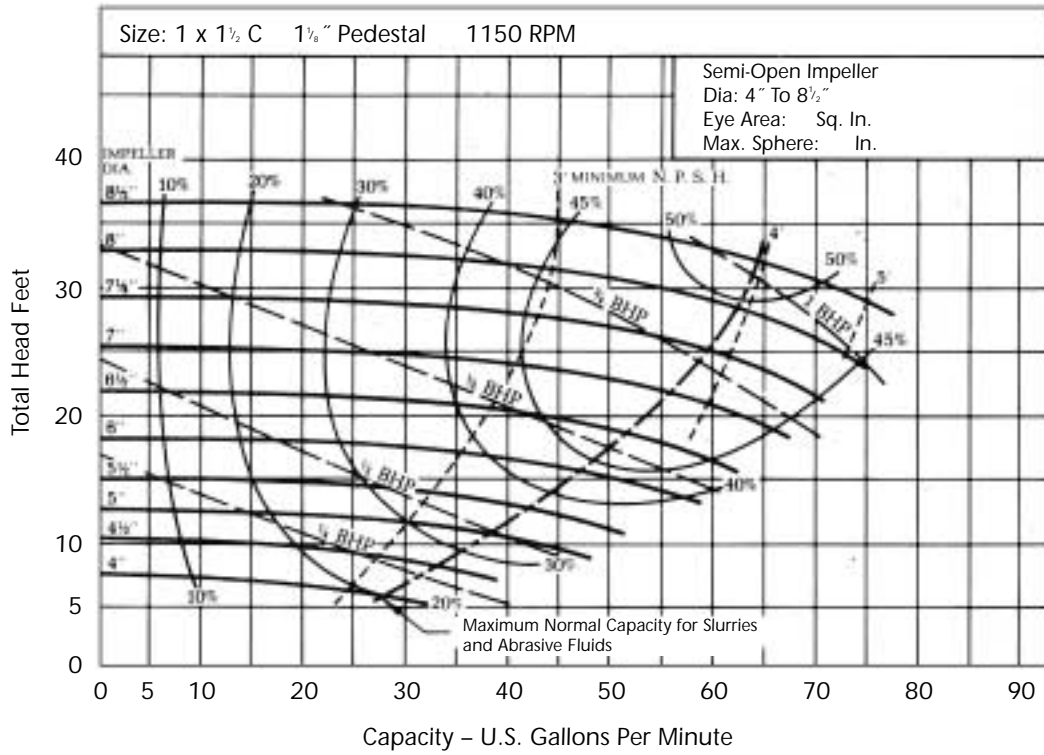

1 x 1½ C 1750 RPM S Pedestal

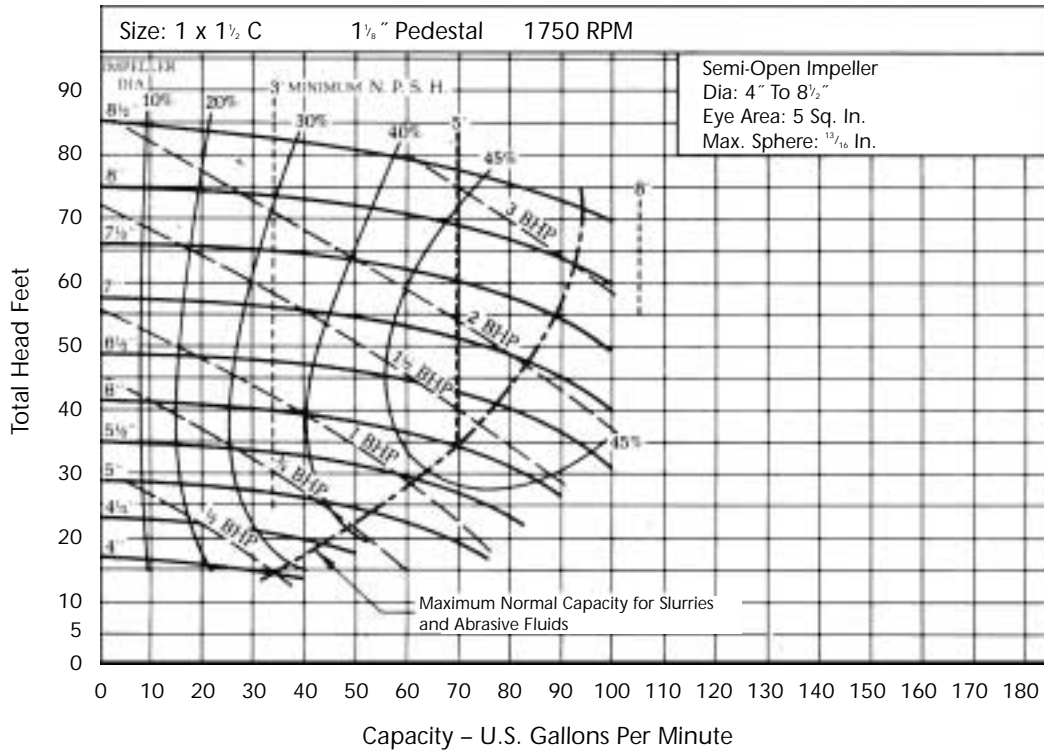

1 x 1½ C      3500 RPM      S Pedestal

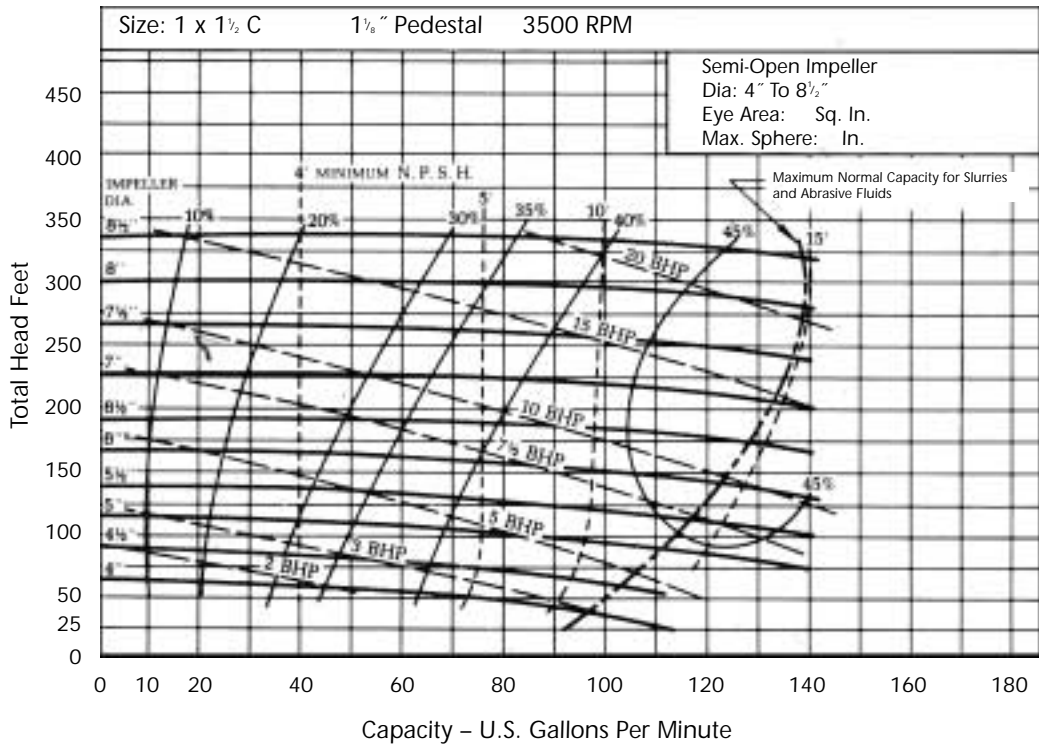

1½ x 2 R & C      1150 RPM      S Pedestal

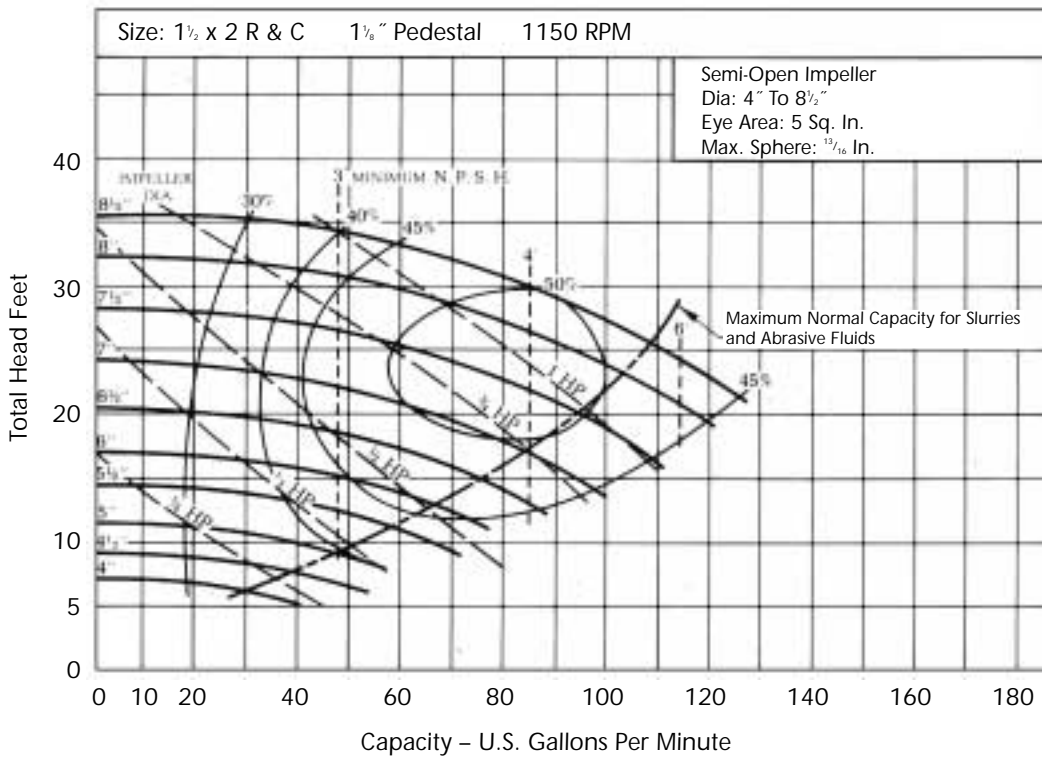

1 1/2 x 2 R & C      1750 RPM      S Pedestal

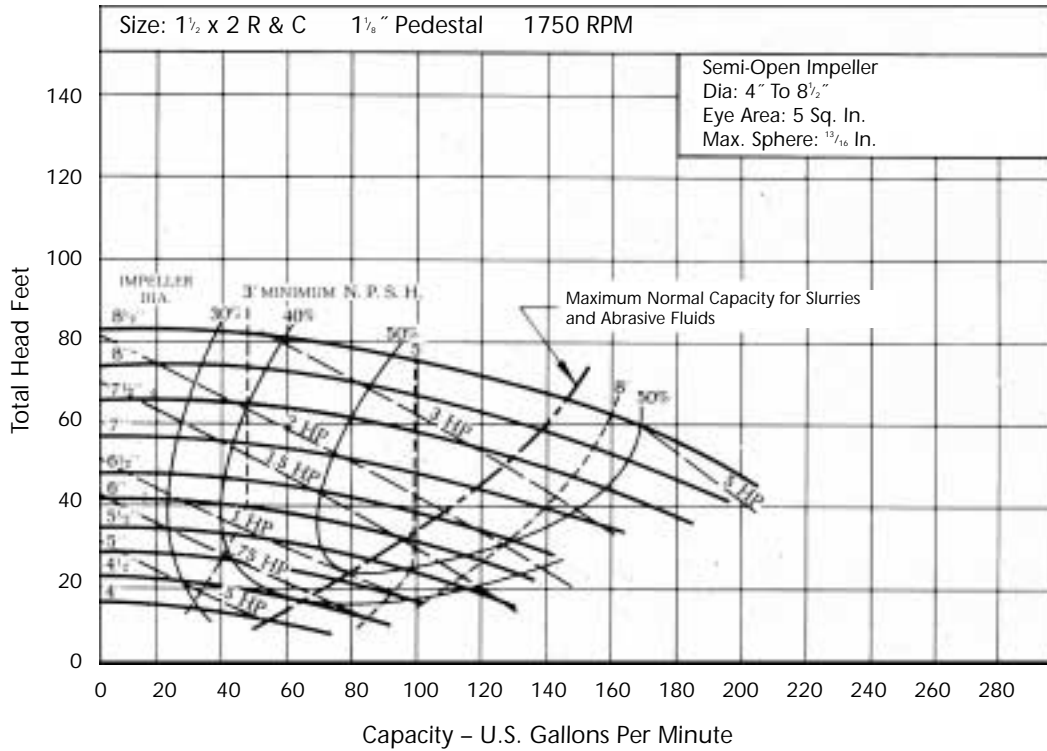

1 1/2 x 2 R & C      3500 RPM      S Pedestal

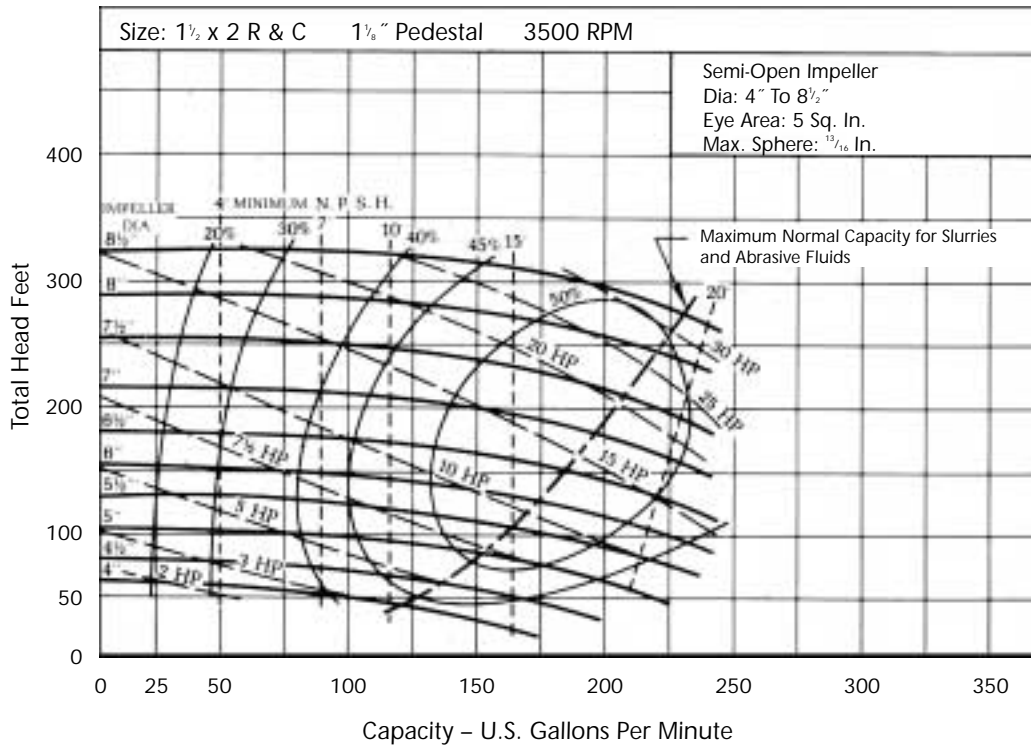



1½ x 2 R & C      1000-3600 RPM      S Pedestal

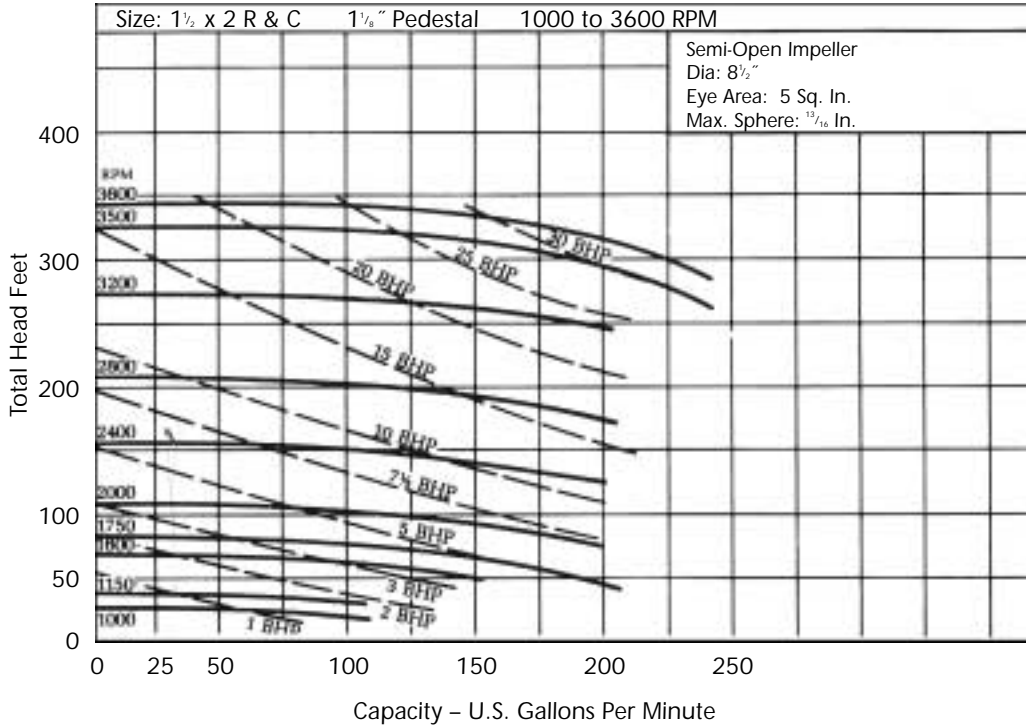

2 x 3 R11 & C11      1150 RPM      S Pedestal

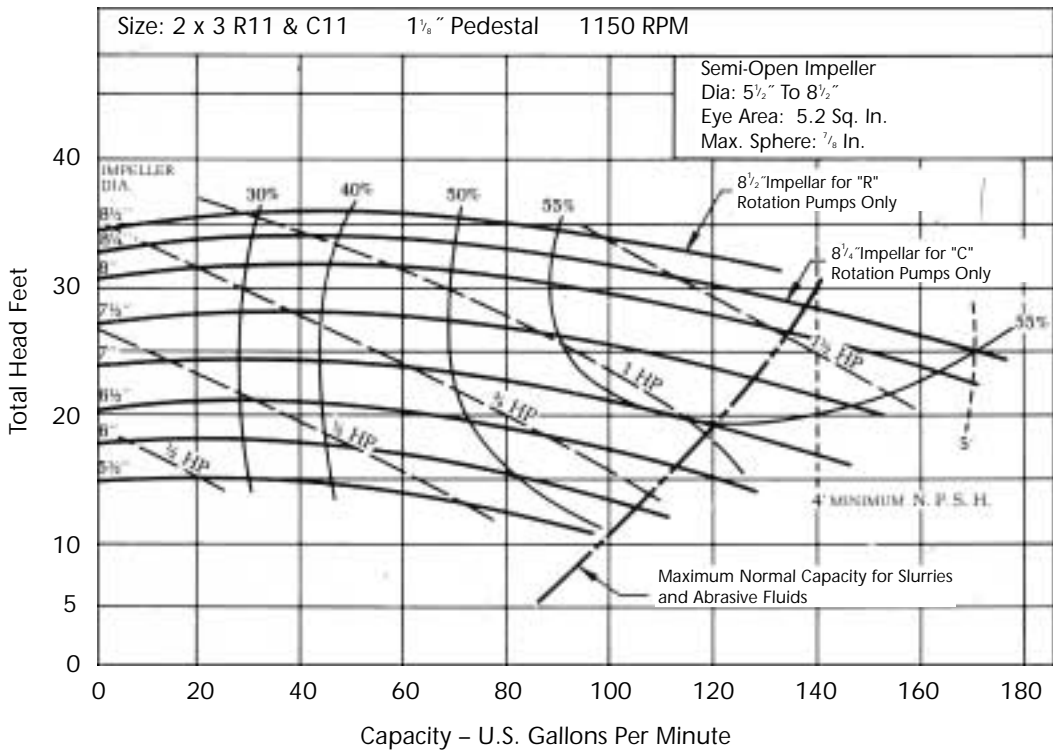

2 x 3 R11 & C11 1750 RPM S Pedestal

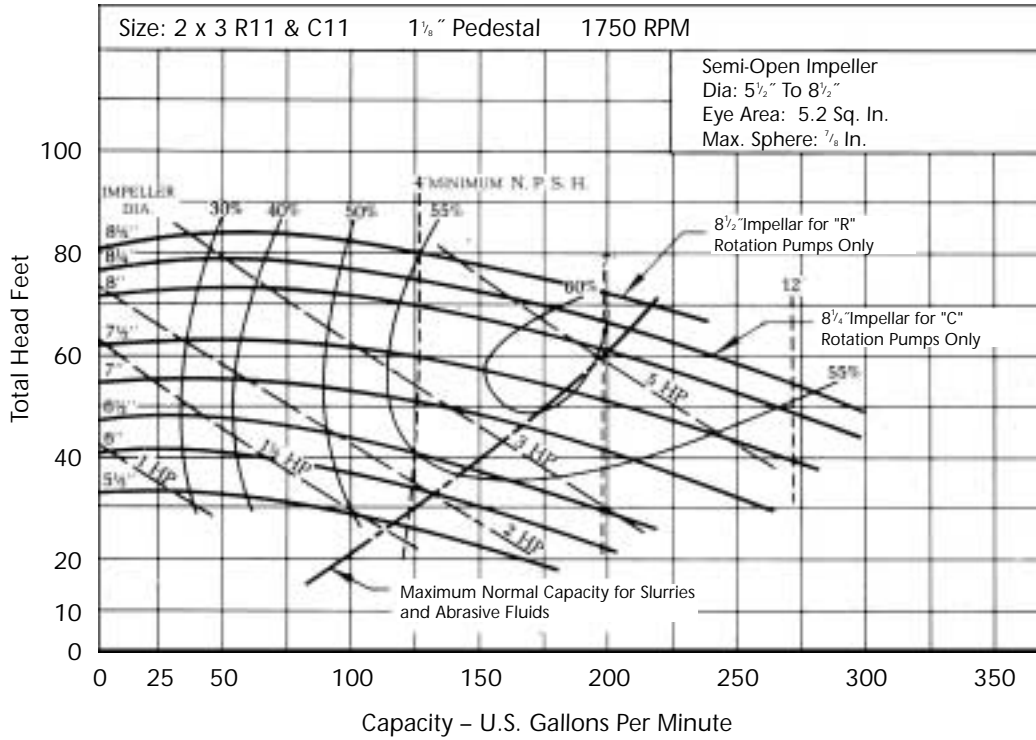

2 x 3 R11 & C11 3500 RPM S Pedestal

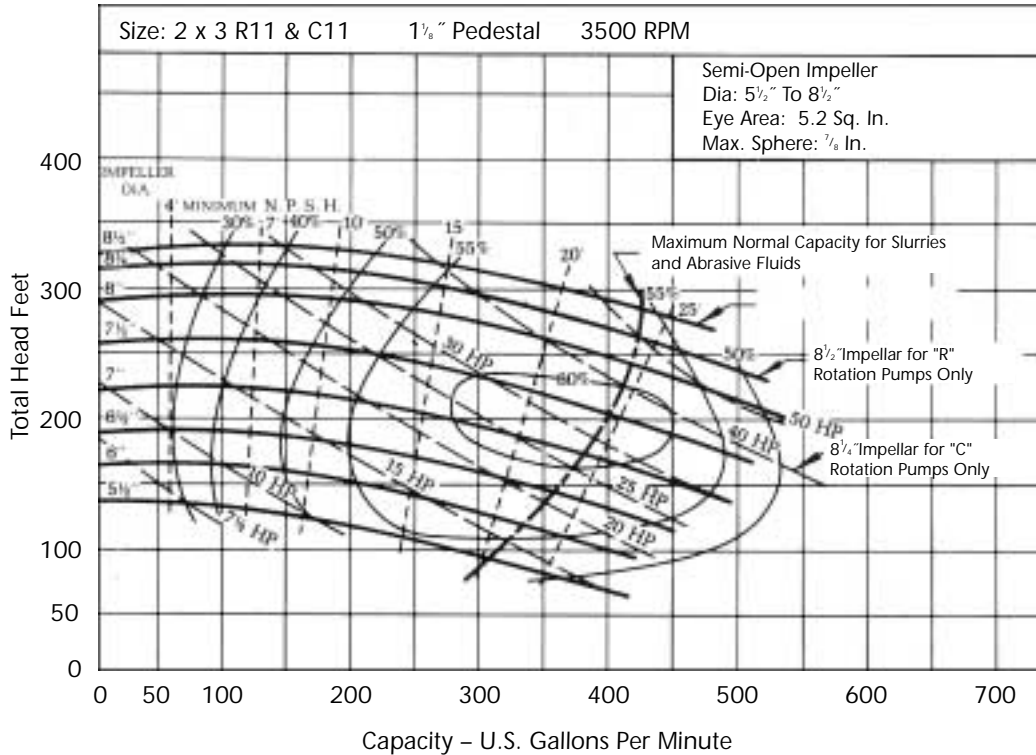

2 x 3 R11      1000-2800 RPM      S Pedestal

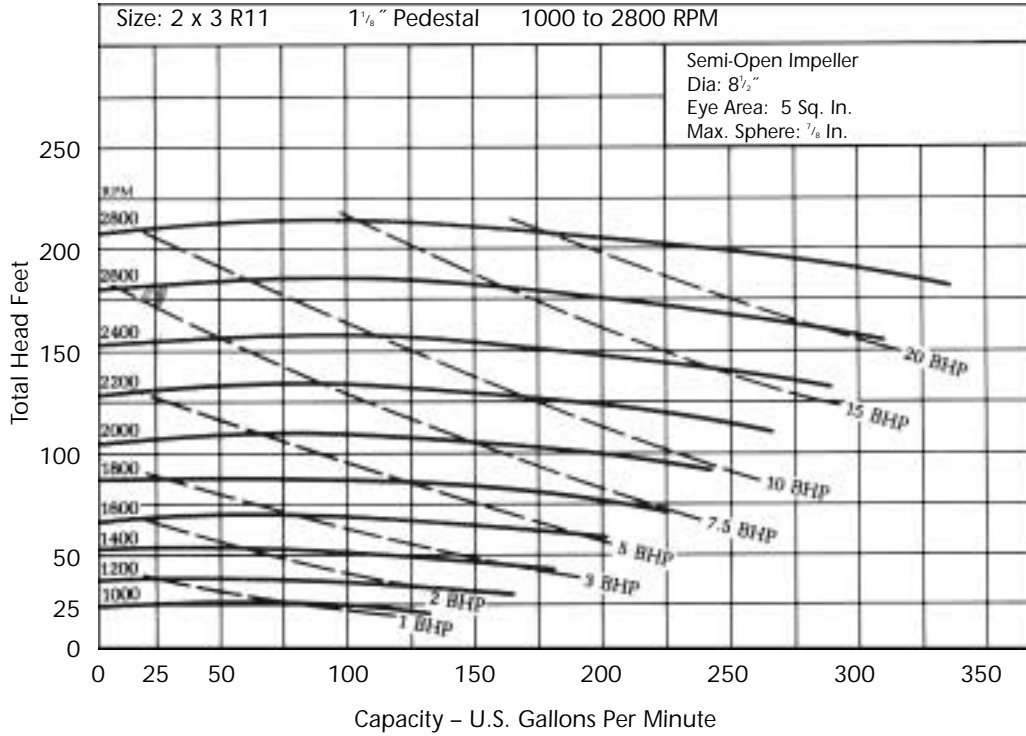

3 x 4 R11      1150 RPM      S Pedestal

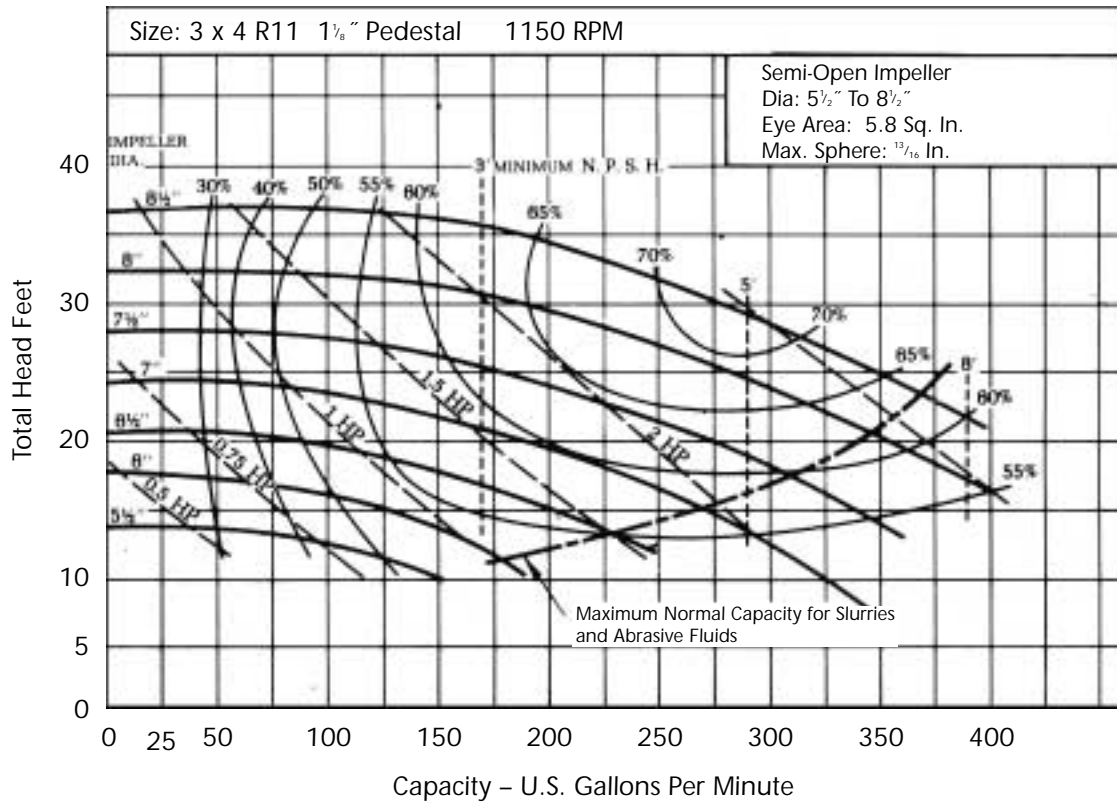

3 x 4 R11 1750 RPM S Pedestal

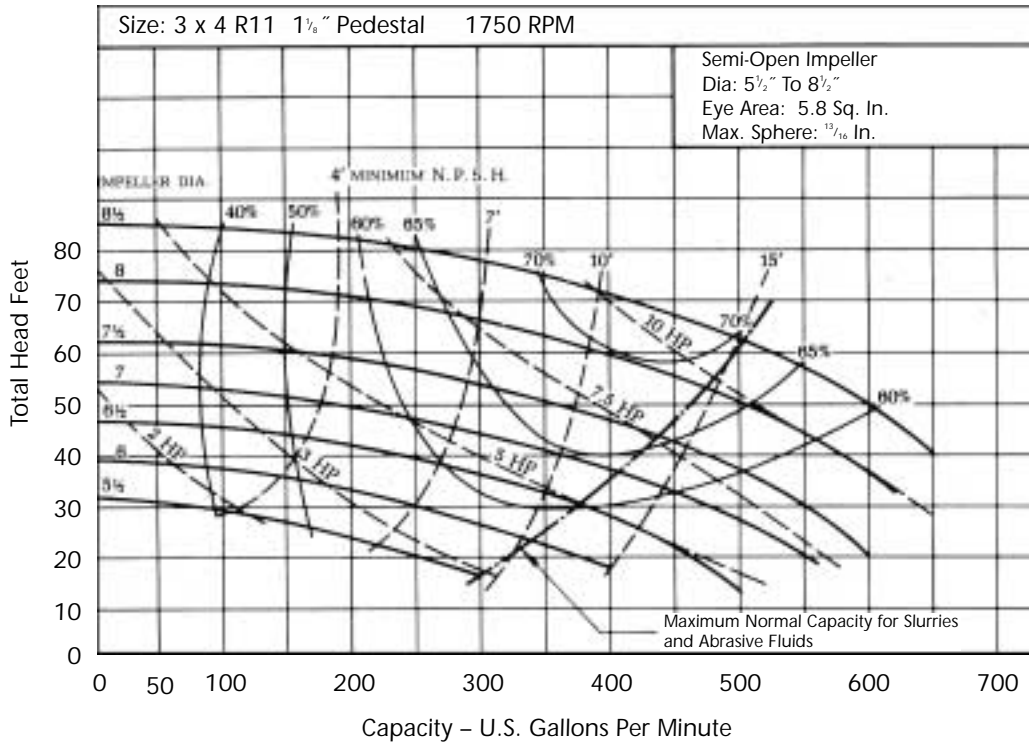

3 x 4 R11 3500 RPM S Pedestal

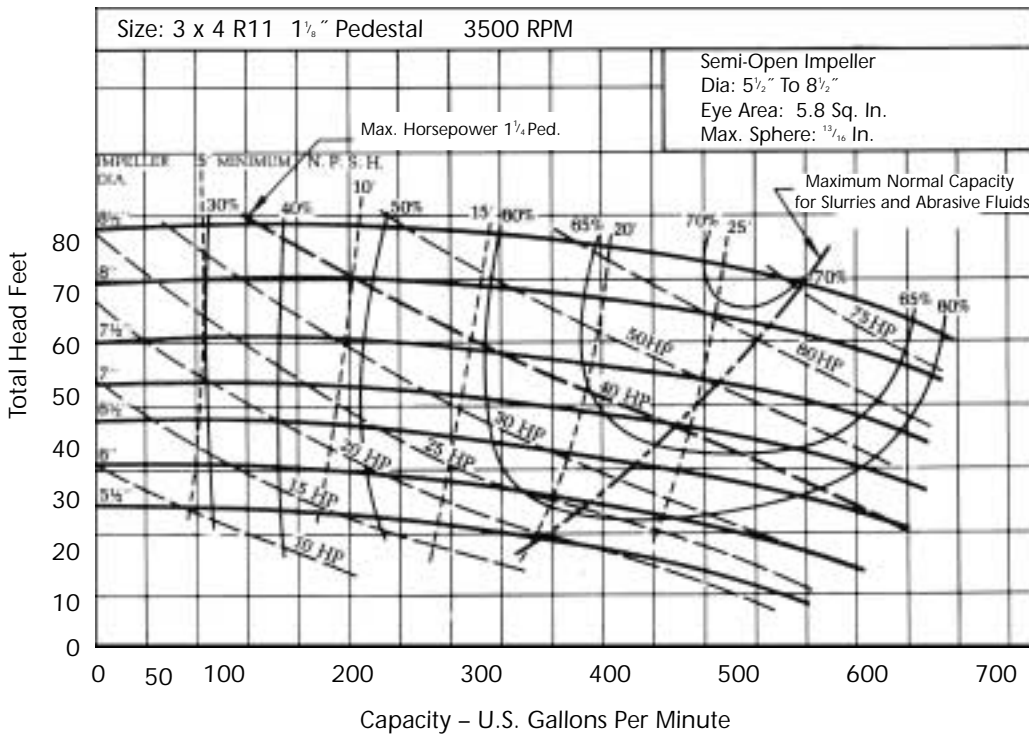



3 x 4 R11 800-3600 RPM S Pedestal

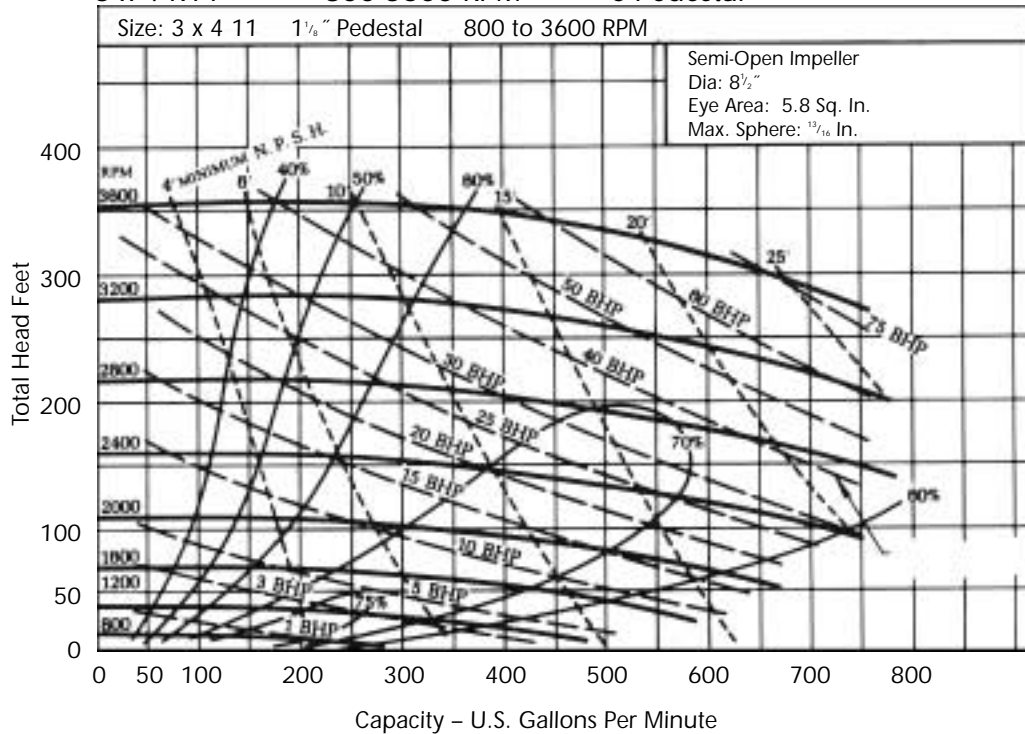

2 x 3 R & C 1150 RPM W Pedestal

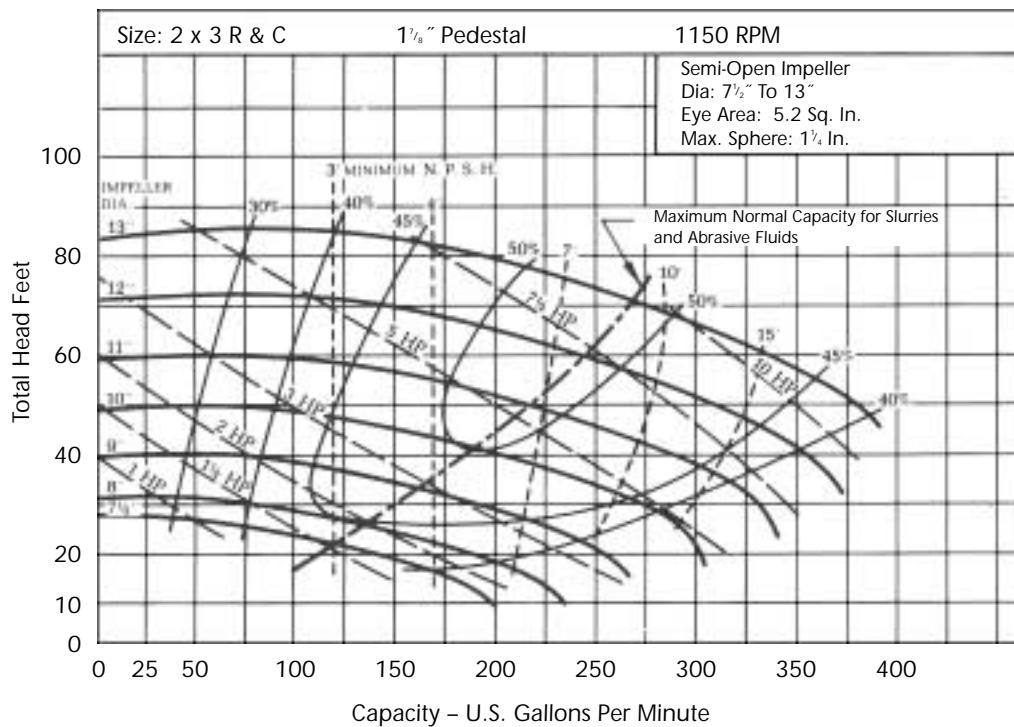

2 x 3 R & C 1750 RPM W Pedestal

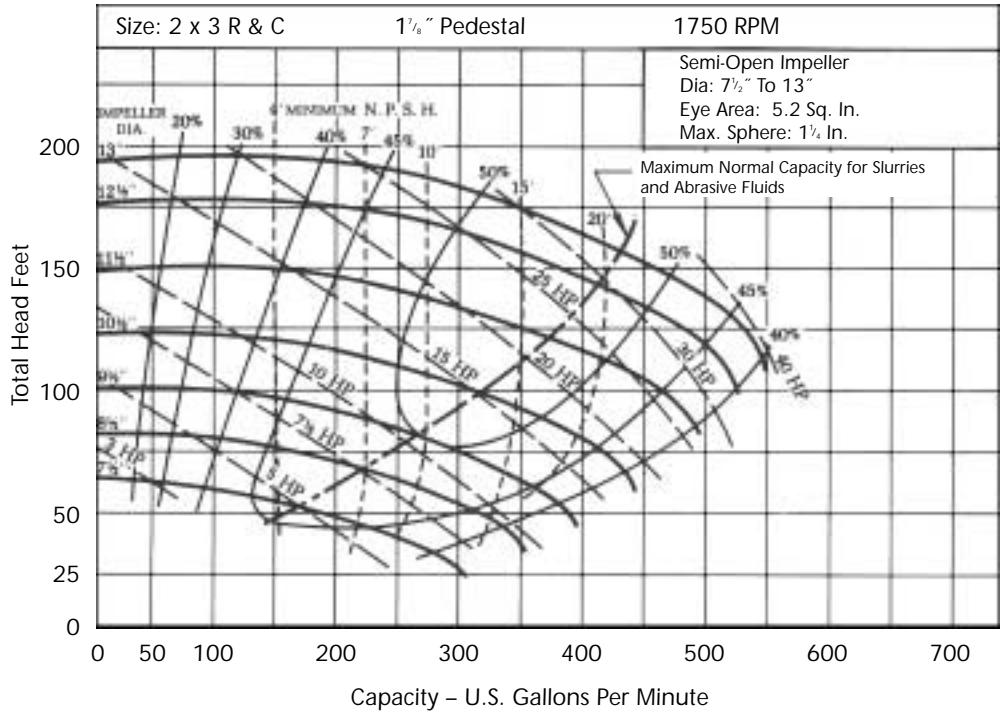

2 x 3 R & C 3500 RPM W Pedestal

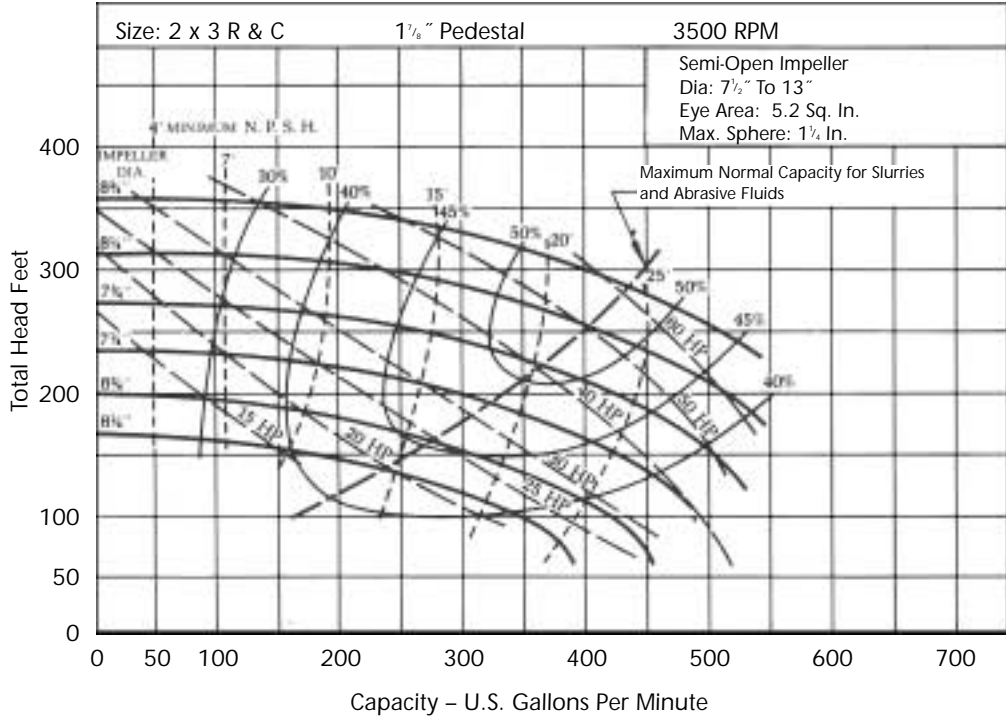

2 x 3 R 700-2500 RPM W Pedestal

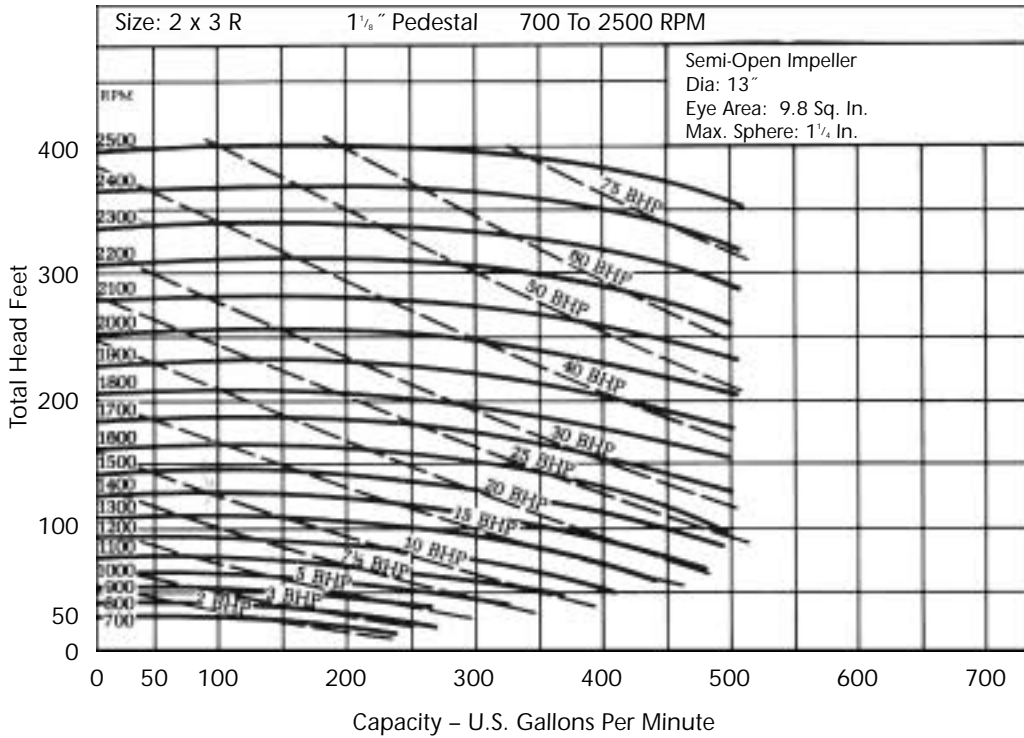

3 x 4 R & C 1150 RPM W Pedestal

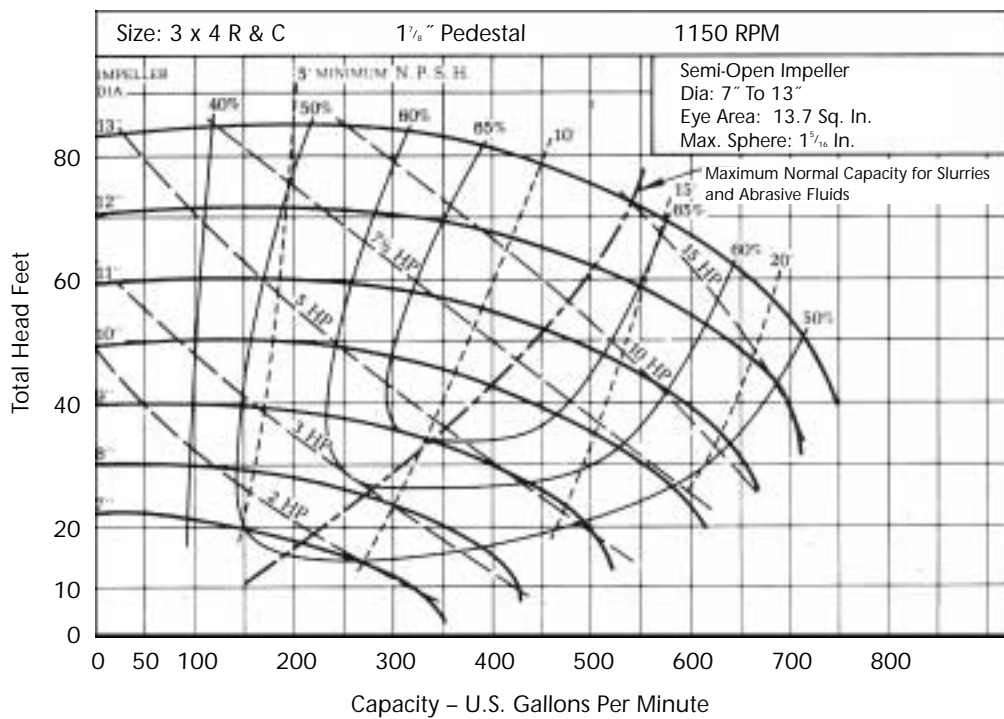

3 x 4 R & C

1750 RPM

W Pedestal

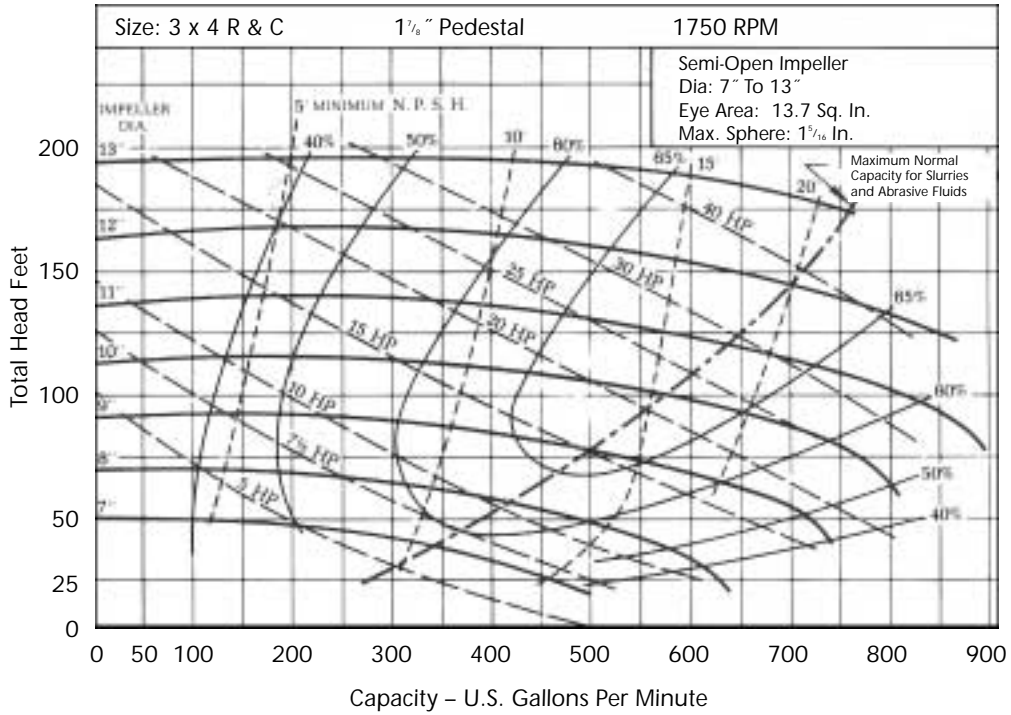

3 x 4 R & C

3500 RPM

W Pedestal

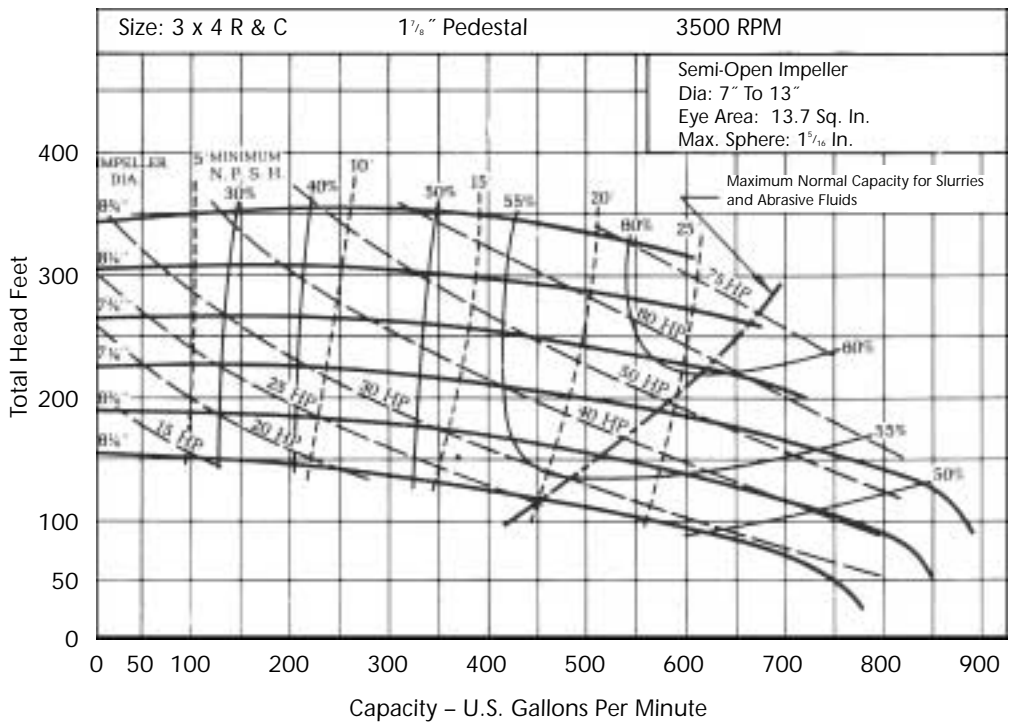



3 x 4 R & C 1000-2400 RPM W Pedestal

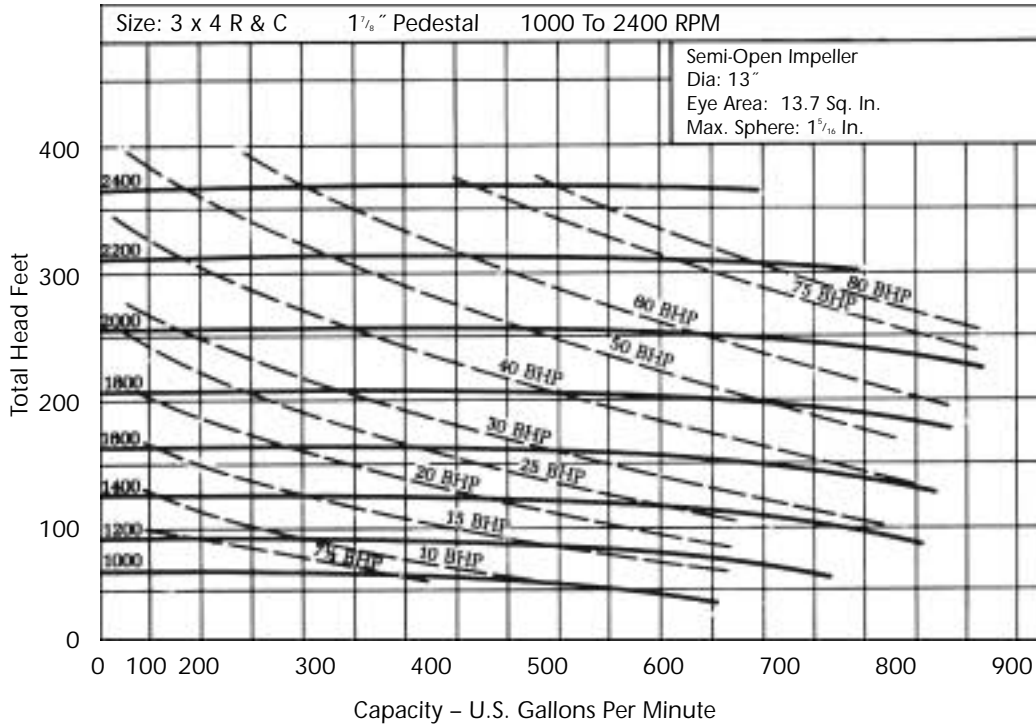

4 x 5 R & C 1150 RPM W Pedestal

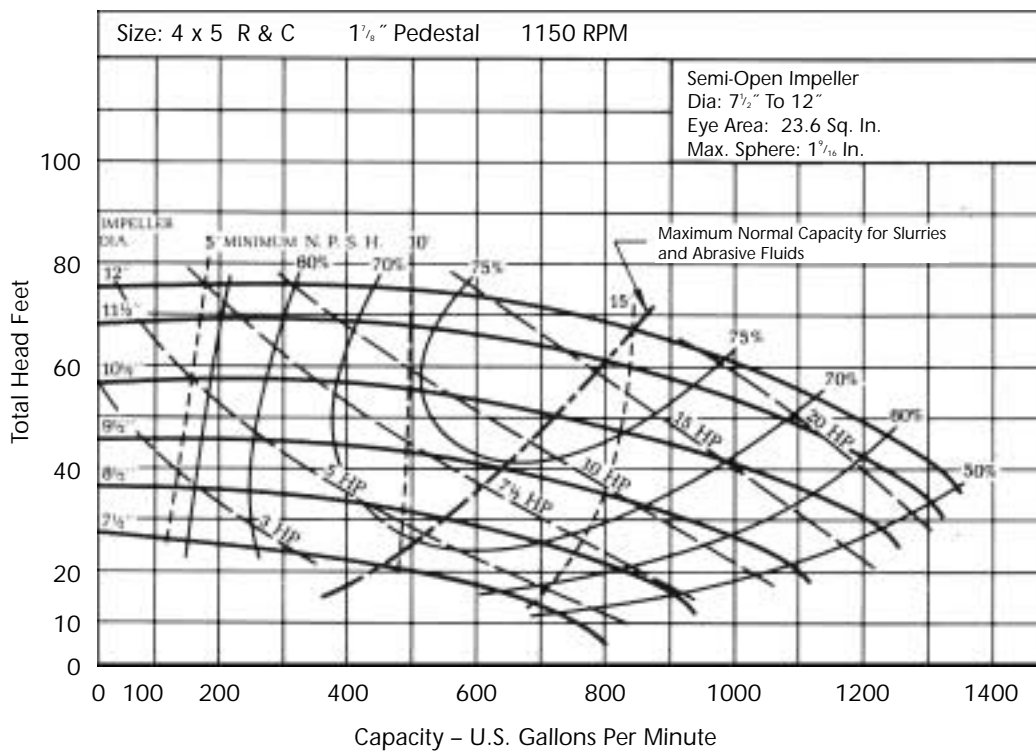

4 x 5 R 1750 RPM W Pedestal

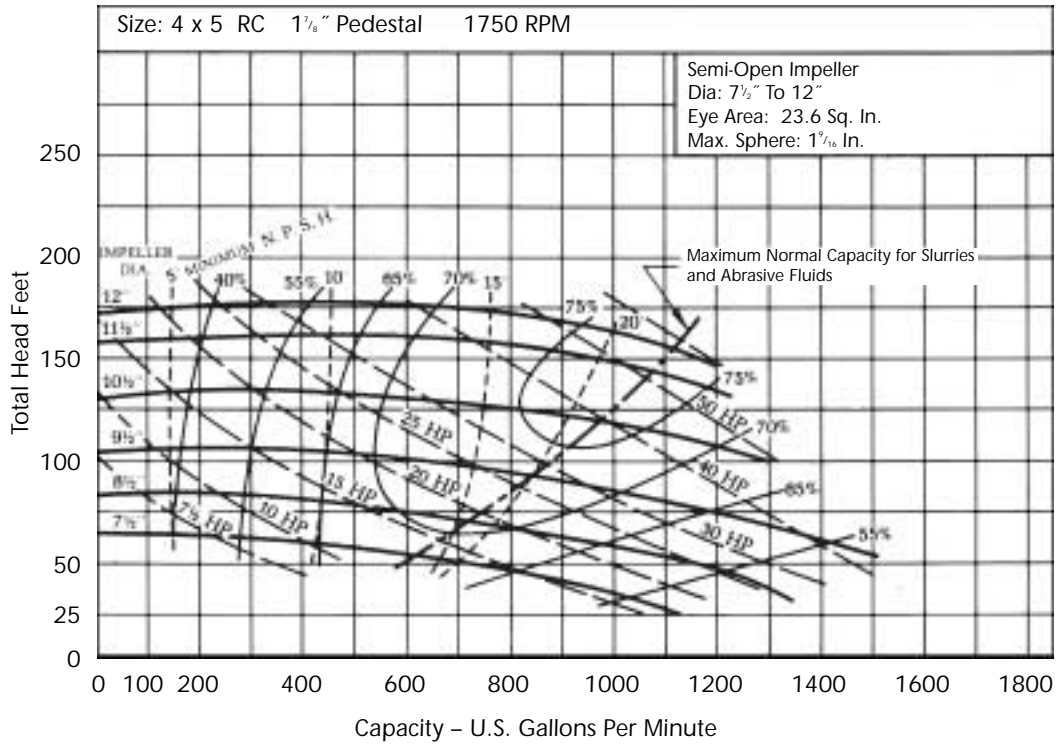

4 x 5 R 800-2000 RPM W Pedestal

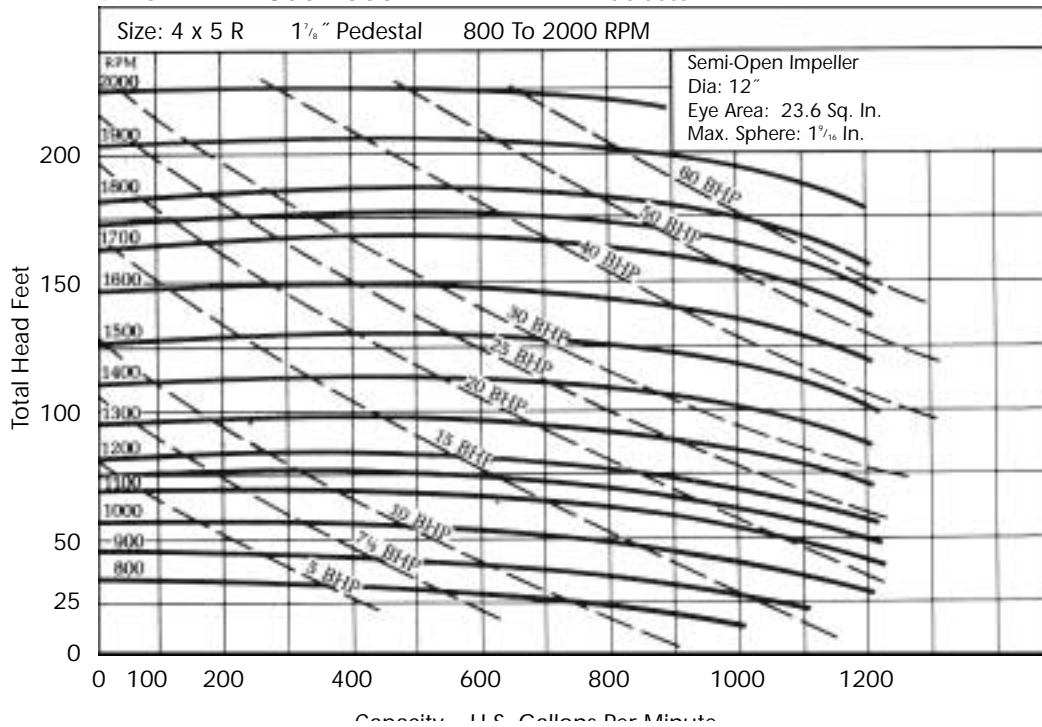

5 x 6 R & C 1150 RPM W Pedestal

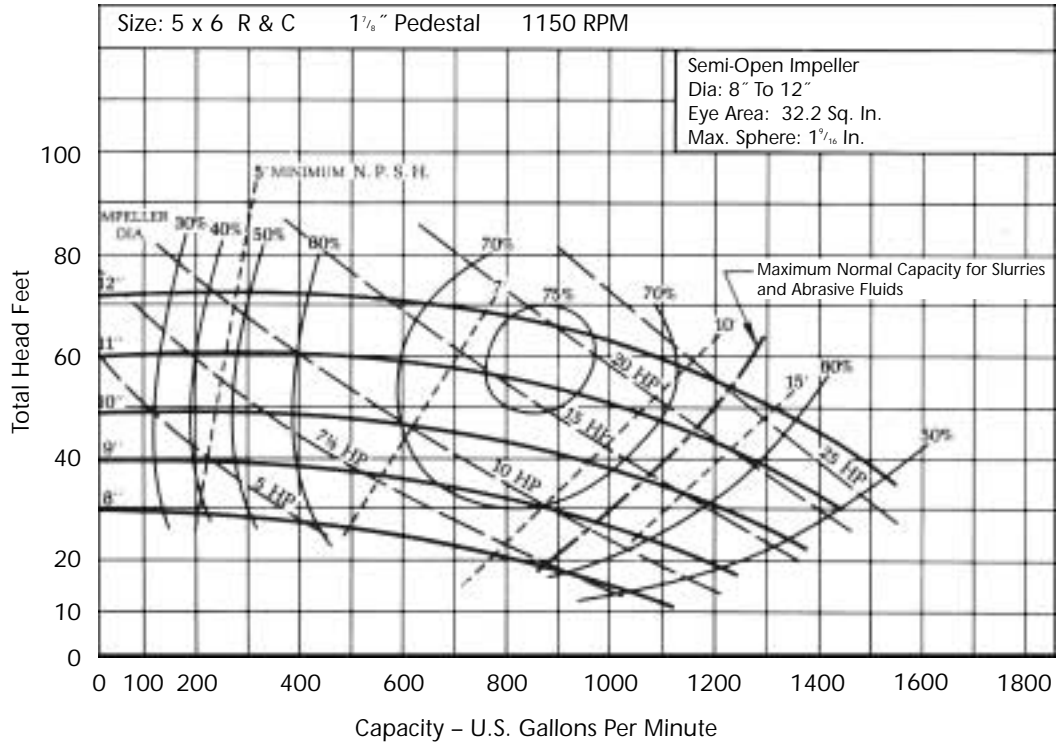

5 x 6 R & C 1750 RPM W Pedestal

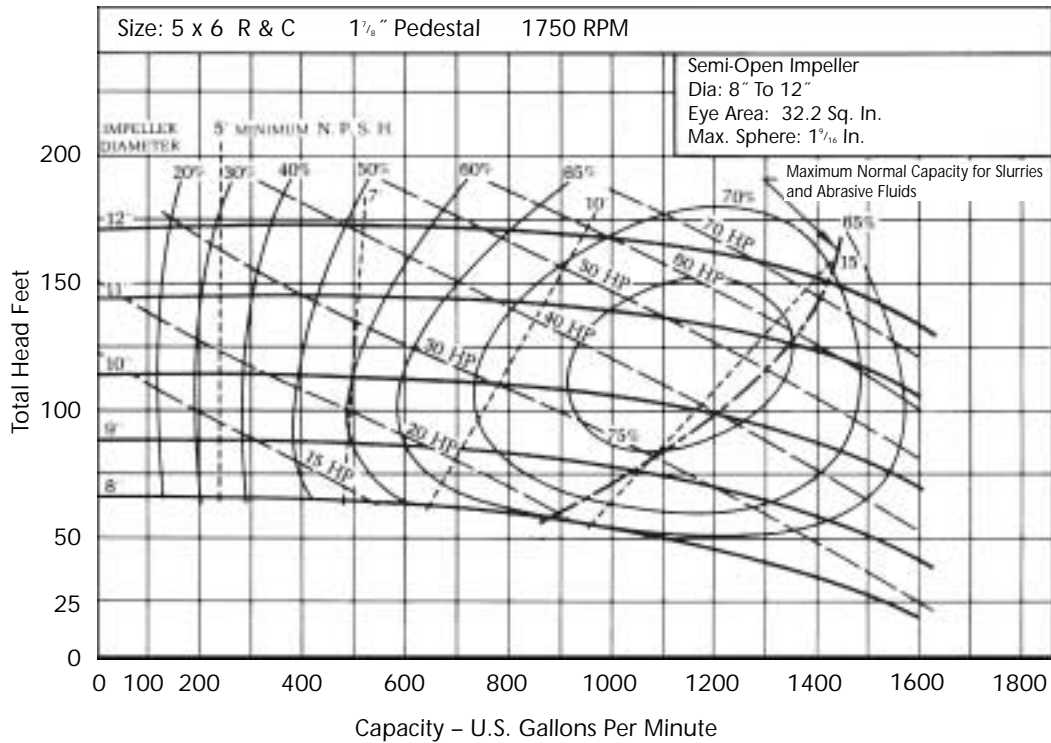

5 x 6 R & C      800-1800 RPM      W Pedestal

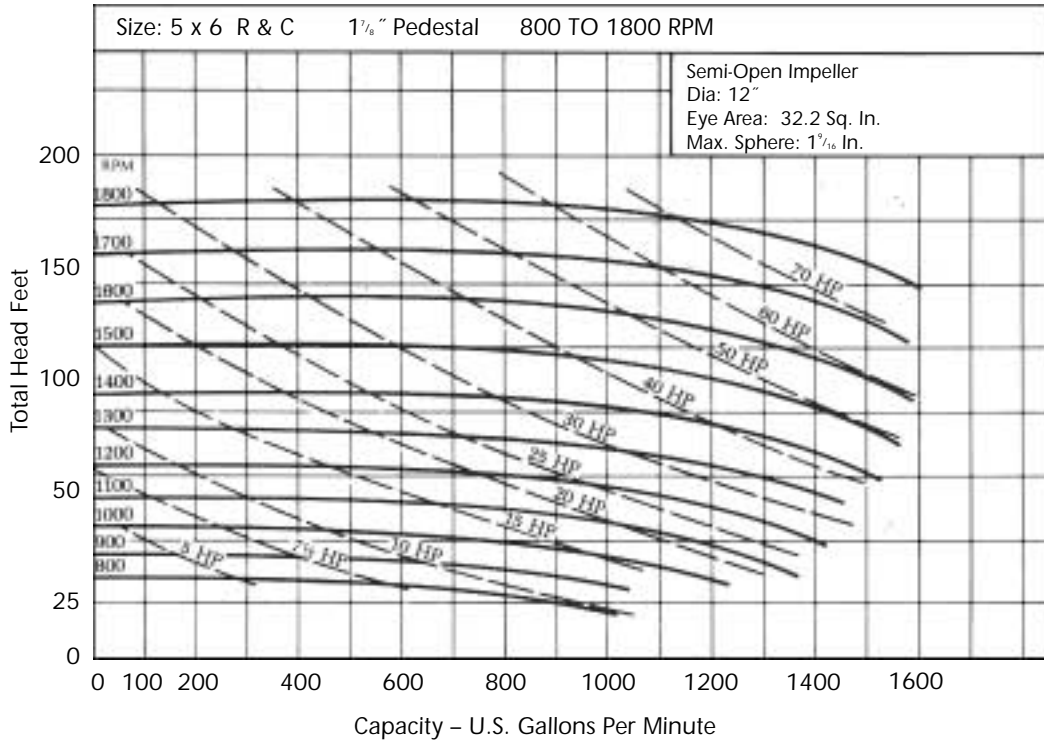

6 x 8 R      1150 RPM      W Pedestal

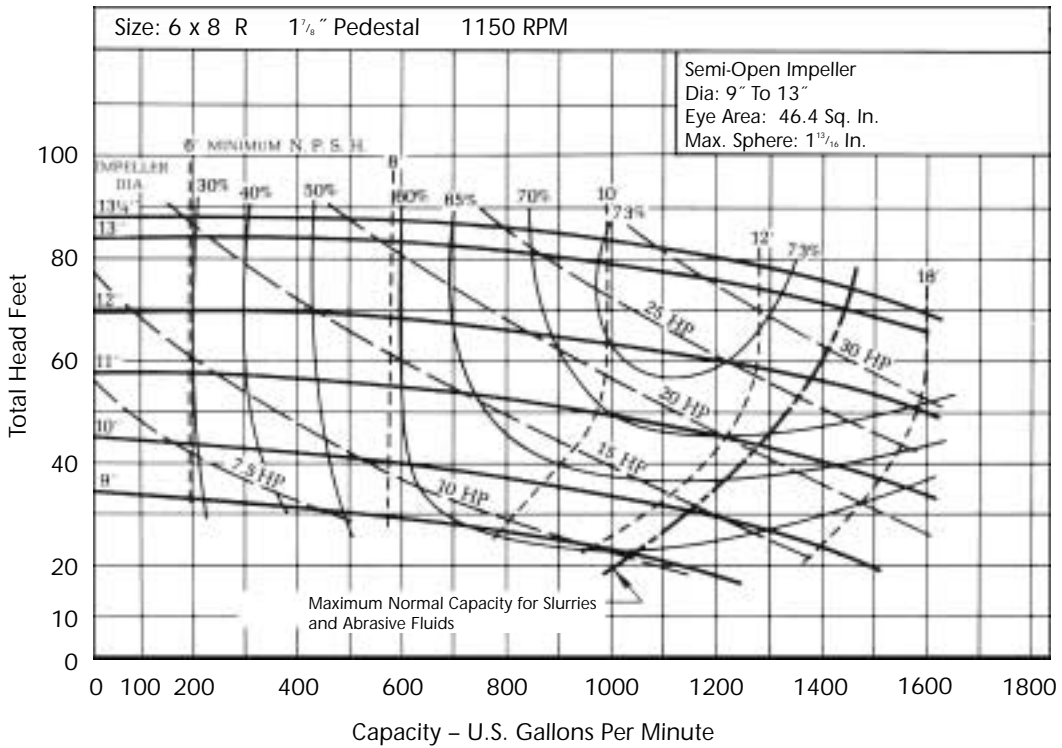



6 x 8 R 1750 RPM W Pedestal

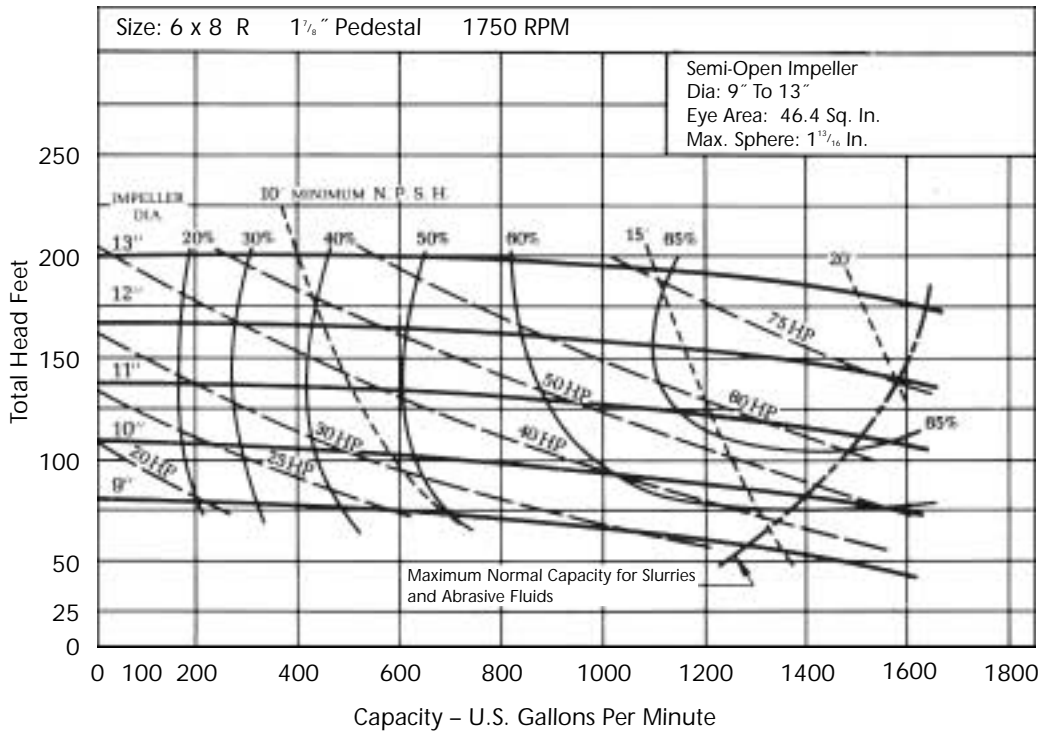

6 x 8 R 700-1700 RPM W Pedestal

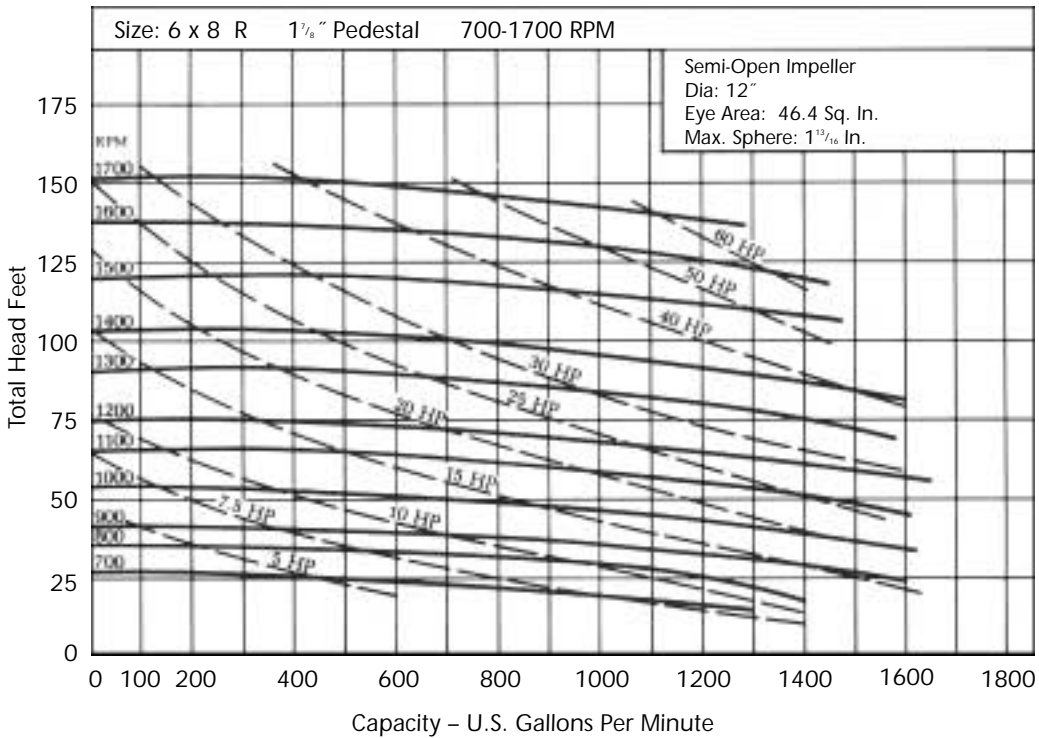



## Materials for various parts in standard pump designations

Parts	Cast Iron (X = 01)	Hard Iron (H30) (X = 30)	Bronze Fitted	Aluminum Bronze (X = 13)	Carbon Steel (X = 08)	316 Stainless (X = 04)	Misaloy 20 (X = 20)
Casing	C.I.	H-30	C.I.	Bronze	Steel	316SS	Msly 20
Impeller	C.I.	H-30	Bronze	Bronze	Steel	316SS	Msly 20
Wear Plate	C.I.	H-30	Bronze	Bronze	Steel	316SS	Msly 20
Shaft	416SS	416SS	316SS	316SS	416SS	316SS	Msly 20
Casing Gasket	Fiber	Fiber	Fiber	Fiber	Kevlar-Graphite	Kevlar-Graphite	Kevlar-Graphite
Packing	Kevlar-Graphite	King Type	Kevlar-Graphite	Kevlar-Graphite	Kevlar-Graphite	Kevlar-Graphite	Kevlar-Graphite

### Materials analysis

The number following each primary materials listing is used to indicate the fluid end material. It is also used with Part Code Numbers. See page 18 for parts ordering information.

#### Cast Iron

#### 01

Silicon	1.50 - 1.65
Manganese	0.70 - 0.80
Sulfur	0.15 Max.
Phosphorus	0.17 Max.
Carbon	3.20 - 3.30

#### Carbon Steel

#### 08

AISI-SAE 1030	
Silicon	.20 - .70
Manganese	.50 - .90
Phosphorus	.05 Max.
Sulfur	.05 Max.
Carbon	.25 - .35

#### Misaloy 20

#### 20

Nickel	29.0
Chromium	20.0
Molybdenum	2.0
Copper	3.0
Manganese	75
Silicon	1.0
Carbon	07 Min.

#### Hard Iron (H-30)

#### 30

Nickel	1.50
Molybdenum	0.50
Chromium	0.40
Silicon	1.35 - 1.50
Manganese	0.75 - 0.9

#### 316SS

ASTM CF-8M	
Chromium	18.00 - 21.00
Nickel	9.00 - 12.00
Molybdenum	2.00 - 3.00
Manganese	1.50 Max.
Silicon	2.00 Max.
Phosphorus	0.05 Max.
Sulfur	0.05 Max.
Carbon	0.12 Max.

#### Aluminum Bronze 13

ASTM B 148 9A	
Copper	86.0 Min.
Aluminum	8.5 - 9.5
Iron	2.5 - 4.0

# Miscellaneous Conversion Data



## Flow

$$\text{GPM} = .03 \times \text{BPD}$$

Barrels/ Hour	Barrels/ Day	GPM
4.2	100	3
10 1/2	500	7 1/2
21	500	15
31 1/2	750	22 1/2
42	1000	30
63	1500	45
83	2000	60
125	3000	90
208	5000	150
312	7500	225
420	10,000	300

To determine specific gravity of mud:  
 Specific Gravity = 
$$\frac{\text{Fluid Weight (Pounds/Gallons)}}{8.34}$$

The pump performance curve shows horsepower for water, which has a specific gravity of 1.0. For fluids which have a specific gravity different from water:  
 Curve HP x Sp. Gr. = Required HP

## Head

$$\text{PSIG} = \frac{\text{Feet} \times \text{Sp. Gr.}}{2.31}$$

$$\text{Feet} = \frac{\text{PSIG} \times 2.31}{\text{Sp. Gr.}}$$

For water, Sp. Gr. = 1.0

Feet	Psi	Psi	Feet
10	4.33	10	23.1
20	8.66	20	46.2
25	10.8	25	57.8
30	13	30	69.3
40	17.3	35	80.9
50	21.6	40	92.4
75	32.48	45	104
100	43.2	50	115.5
150	64.8	60	138.6
200	86.4	75	173.2
250	108	100	231
300	130	125	288.7
350	151.6	150	346.5
400	172.8	175	404.2
450	195	200	462

## To determine horsepower for pumping weighted fluids:

The Pump Performance Curve shows horsepower for pumping clear water with a specific gravity of 1 and a weight of 8.34 lb/gal. For fluids with a higher specific gravity than plain water, correct the Pump Performance Curves in the following manner:

1. Find fluid weight in lb/gal.
2. Multiply horsepower shown on the curve by fluid weight in lb/gal; divide by 8.34.

$$\text{Corrected HP} = \frac{\text{Curve Brake HP} \times \text{Fluid Wt./Gallon}}{8.34}$$

## How to select the pump for the application using the Head Capacity Range Charts on pages 11 through 22.

1. Select the impeller size.
2. Calculate the required horsepower.
  - a. Read horsepower from curve at operating point on impeller (selected as accurately as possible) then:

$$\text{Brake Horsepower Required} = \text{Hp curve} \times \text{SP. GR. Fluid}$$

- b. Alternate method -

Read efficiency at the operating point.

$$\text{Brake Horsepower} = \frac{(\text{GPM}) (\text{Feet Head}) (\text{SP. GR.})}{(3960) (\text{Efficiency})}$$

3. Calculate your system NPSH available in feet.

NPSH available =

$$\frac{\text{PA} - \text{Friction Loss}}{\pm \text{Elevation} - \text{Vapor Pressure}}$$

where...

PA - absolute pressure above liquid in feet of fluid.

Absolute pressure =

Gauge pressure + atmospheric pressure

Elevation = distance from surface of liquid on suction side to center line of pump in feet (above +; below -)

Vapor pressure = vapor pressure fluid at pumping temperature in feet of fluid.

Vapor pressure of water for estimating:

Temperature	Vapor pressure Feet of fluid
80° F	1.2
120° F	3.9
140° F	6.8
160° F	11.2
180° F	17.8

4. Red NPSH required from curve.

a. NPSH available must be equal to or greater than NPSH required or pump will cavitate.

b. If NPSH required is great than NPSH available consider:

- 1) Using larger suction pipe to lower losses.
- 2) Raising fluid level.
- 3) Oversizing pump.
- 4) Lowering pump speed and increasing impeller diameter to meet same head.

### Worldwide Availability

MISSION pumps & expendables are available from leading supply stores everywhere.

For your nearest distributor call toll-free 1-800-800-4110.

### Comprehensive Capabilities

In addition to its broad line of drilling and production fluid end expendables and centrifugal pumps, MISSION also offers other auxiliary products including:

- Valve seat pullers
- Piston, rod, and liner removal tools
- Washpipes and packing
- Mud hoppers

The information and data in this catalog are accurate to the best of our knowledge and belief, but are intended for general information only. Applications suggested for the materials are described only to help readers make their own evaluation and decisions, and are neither guarantees nor to be construed as express or implied warranties of suitability for these or other applications. MISSION makes no warranty either express or implied beyond that stipulated in MISSION's Standard Terms and Conditions of Sale.

FLUID KING®, MISSION®, SUPREME, SUPER SERVICE, MASTER II, SILVER TOP, SERVICE MASTER, FLEX-LIP, GREEN DUO, MAGNACHROME, MAGNUM I, VORTEX, ROUGHNECK, SANDMASTER, and MAGNUM XP are trademarks of NATIONAL-OILWELL. KEVLAR® AND DELRIN® are trademarks of DuPont. EZ-SEAL is a registered trademark of Utex Industries Inc.

### MISSION Products Group Sales & Service Locations.

#### World Headquarters

MISSION Products Group  
1530 Sam Houston Prkwy N  
Houston, Texas 77043

#### Mailing Address

P.O. Box 2108, Houston, TX 77252  
Phone: 713-462-4110  
Telex: 422397 ITT  
Fax: 713-937-7151

#### Distribution Center

12225 FM 529  
Houston, Texas 77041  
Phone: 713-462-4110  
Toll Free: 800-800-4110  
Fax: 713-937-7151

#### Worldwide Stocking Locations U.S.A.

**California**, Bakersfield  
Phone . . . . . 805-588-8001  
Fax . . . . . 805-588-2117

#### Illinois

Clay City  
Phone . . . . . 618-676-1535  
Fax . . . . . 618-676-1710

#### Louisiana

New Iberia  
Phone . . . . . 318-365-2582  
Fax . . . . . 318-365-0120

#### Mississippi

Laurel  
Phone . . . . . 601-428-0603  
Fax . . . . . 601-649-0605

#### New Mexico

Farmington  
Phone . . . . . 505-327-0470  
Fax . . . . . 505-325-1083

#### Ohio

Wooster  
Phone . . . . . 330-264-9441  
Fax . . . . . 330-264-9444

#### Oklahoma

Oklahoma City  
Phone . . . . . 405-670-8771  
Fax . . . . . 405-670-8775

#### Texas

Alice  
Phone . . . . . 512-664-9572  
Fax . . . . . 512-664-8991

#### Houston

Phone . . . . . 713-462-4110  
Fax . . . . . 713-937-7151

#### Kilgore

Phone . . . . . 903-983-3531  
Fax . . . . . 903-984-0299

#### Odessa

Phone . . . . . 915-368-0014  
Fax . . . . . 915-368-0171

#### Wyoming

Casper  
Phone . . . . . 307-235-2751  
Fax . . . . . 307-235-9003

#### International:

**Canada**, Edmonton  
Phone . . . . . 780-414-2100

#### Scotland

Aberdeen  
Phone . . . . . 44-1224-875071  
Fax . . . . . 44-1224-248675

#### Norway

Stavanger  
Phone . . . . . 47-51-44-45-56  
Fax . . . . . 47-51-81-83-96

#### U.A.E.

Abu Dhabi  
Phone . . . . . 971-2-553456  
Fax . . . . . 917-2-559632

#### Singapore

Phone . . . . . 65-542-7728  
Fax . . . . . 65-542-7123



**NATIONAL OILWELL**  
**Mission Products Group**

[www.natoil.com](http://www.natoil.com)