

KEYSTONE

Thin Disc Resilient Seated Butterfly Valves Sizes 1 thru 20-inch to 150 psi

Features and Benefits

- One-piece, thin profile, 316 Stainless steel disc/stem provides minimum obstruction to flow, resulting in highest C_v , lowest pressure drops and best control characteristics. Also available with PTFE, NBR or EPDM molded disc.
- Triple function, resilient dovetail seat isolates body and stem from line media, provides drop-tight shutoff of line media at full-rated pressure and permits convenient and economical replacement in the field.
- Heavy duty, corrosion resistant top bushing provides upper stem support, absorbs actuator sideloads and extends valve cycle life.
- Bi-directional, self-adjusting double V-cup stem seals prevent external contaminants from entering the valve.
- Split body design enables easy field replacement of seat and disc/stem and permits direct mounting of Keystone actuators without the use of couplings or brackets.

General Application

Figure 990 (wafer) and Figure 920 (lug) are used when sanitary service or corrosion resistance is required. Heavy duty applications include chemical, food and beverage, pharmaceutical, pulp and paper, mining and power industries. Available with PTFE lining for light corrosive services and rubber lining for light abrasive services.



Technical Data

Sizes:

- 1 thru 20-inch (Figure 990) Wafer
- 2 thru 20-inch (Figure 920) Lug

Pressure Ratings:

- 1 thru 12-inch – 150 psi
- 14 thru 20-inch – 75 psi
- PTFE or elastomer mold disc
 - 2 thru 12-inch – 100 psi
 - 14 thru 20-inch – 75 psi
- White NBR seats
 - 2 thru 20-inch – 50 psi

Flange Standard

Figure 990 is a resilient-seated, wafer-style, butterfly valve suitable for installation between ANSI Class 125/150 flanges.

Figure 920 provides drilled and tapped lugs around the valve body, compatible with ANSI Class 125/150 flange standards.

tyco / Flow Control

Total Flow Control Solutions™

Keystone is either a trademark or registered trademark of Tyco International Services AG or its affiliates in the United States and/or other countries. All other brand names, product names, or trademarks belong to their respective holders.

Materials

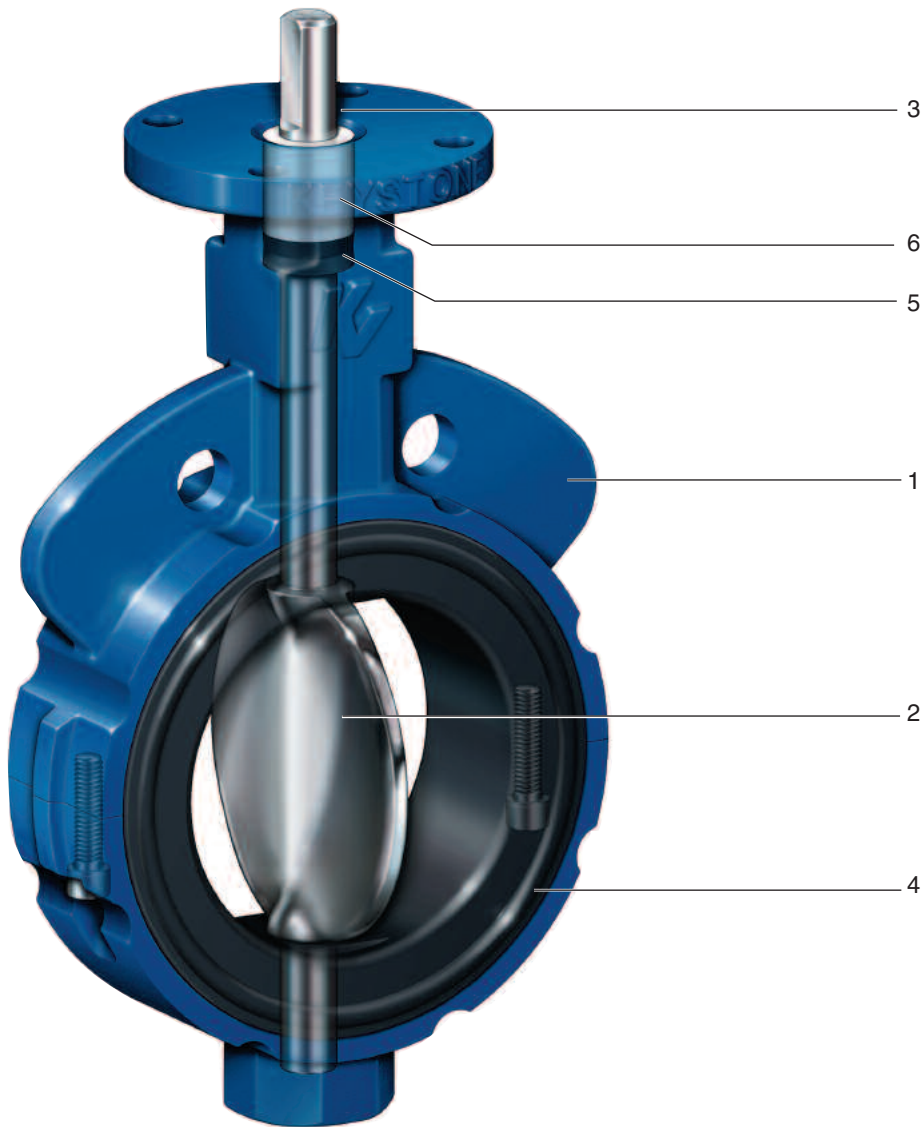

Materials

Part	Material	Material Standard
1. Two-piece body with top plate	Cast iron Ductile iron (Lug style only) 316 Stainless steel	ASTM A-126, Class B ASTM A-395 GR 60/40/18 ASTM A-743 CF8M ¹
2. Thin profile disc	316 Stainless steel Steel Teflon [®] molded ² Steel EPDM molded ² Steel NBR molded ²	
3. Stem	316 Stainless steel	
4. Seat	NBR food grade (0°F thru 212°F) EPDM food grade (-40°F thru 250°F) PTFE-lined EPDM (-20°F thru 300°F) PTFE-lined NBR (0°F thru 250°F)	
5. Stem packing	NBR	
6. Upper stem bushing	Polyester	

Notes

1. Not available on 2 1/2-inch and 5-inch. Stainless steel bodies, 2 thru 6-inch, include upper and lower stem bearings.
2. Not available on 1-inch, 1 1/2-inch, 2 1/2-inch and 5-inch.
3. Teflon[®] is a registered trademark of E.I. du Pont de Nemours Company.

PTFE Lined

The Keystone Figure 990 and 920 is offered with PTFE lining for mildly corrosive services or an elastomer lining for mildly abrasive services.



Flow Control Characteristics

While most butterfly valves achieve an equal percentage characteristic, the Keystone thin-profile disc design does so at a significantly higher capacity through the valve's full travel. This results in not only 100:1 rangeability (Maximum C_v /Minimum C_v), but also greatly increased turndown ratio (Maximum Flow/Minimum Flow).

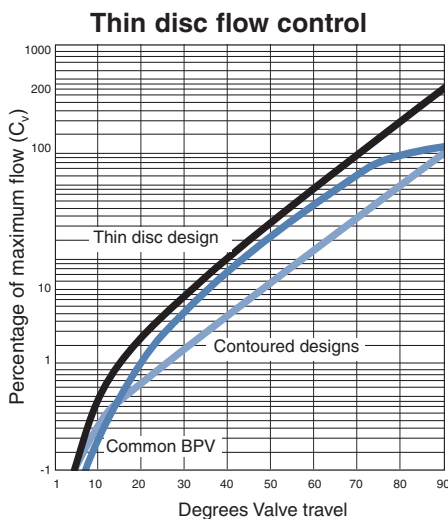

Flow Coefficient (C_v)

Valve Size (in)	Angle of Disc Opening								
	10°	20°	30°	40°	50°	60°	70°	80°	90°
1	0.07	0.7	2.8	4.8	8.3	13	24	42	89
1 1/2	0.16	1.6	6.5	11.4	20.0	31	55	88	162
2	0.30	2.7	10.7	18.7	32.0	51	91	161	267
2 1/2	0.45	4.5	18.0	32.0	54.0	86	153	273	451
3	0.70	6.9	27.7	49.0	83.0	132	235	419	693
4	1.30	13.1	52.6	92.0	158.0	250	447	795	1,314
5	2.10	21.1	84.3	148.0	253.0	400	717	1,275	2,108
6	2.80	27.9	112.0	195.0	335.0	530	848	1,690	2,790
8	5.20	52.1	208.0	365.0	625.0	990	1,770	3,150	5,208
10	8.30	83.1	332.0	582.0	997.0	1,580	2,825	5,025	8,308
12	12.00	120.0	481.0	842.0	1,440.0	2,286	4,090	7,275	12,030
14	15.00	150.0	600.0	1,050.0	1,800.0	2,850	5,100	9,075	15,000
16	20.00	200.0	798.0	1,397.0	2,395.0	3,792	6,788	12,075	19,960
18	25.80	258.0	1,032.0	1,805.0	3,095.0	4,900	8,768	15,600	25,790
20	32.20	322.0	1,290.0	2,257.0	3,870.0	6,125	10,960	19,500	32,240

Based on independent laboratory testing.

Figure 990 Wafer

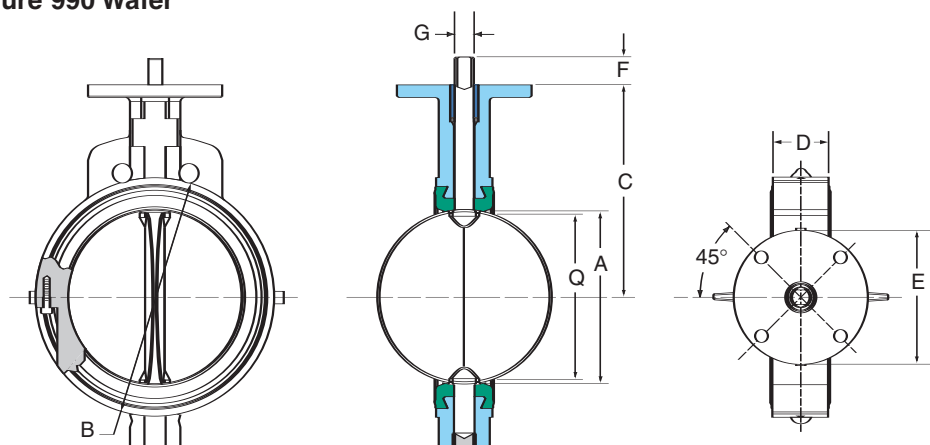
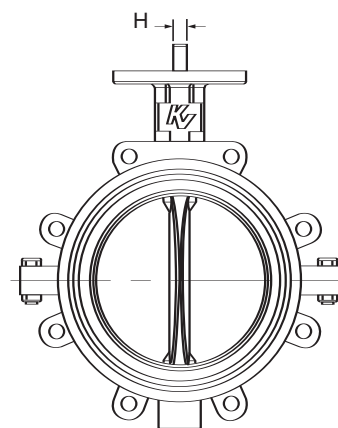

Figure 920 Lug



Cast and ductile iron body (inches)

Size	A	B	C	D	E	F	G	H(1)	Q(3)	Top Plate Drilling			Tapped Lug Data			Weight 990	(lbs.) 920	Adapt Code	
										Key	Bolt Circle	No. Hole Dia.	Bolt Circle	No. Holes	Tap Size				
1	1 1/4	2 7/16	3 1/8	1 1/8	2 1/4	3/4	3/8	1/4	5/8	N/A	1 3/4	4	9/32	N/A	N/A	N/A	1 1/2	N/A	AAA
1 1/2	1 3/4	3 7/32	3 23/32	1 3/16	2 1/4	3/4	3/8	1/4	1 7/16	N/A	1 3/4	4	9/32	N/A	N/A	N/A	2 1/4	N/A	AAA
2	2	4 1/8	5 1/2	1 5/8	4	1 1/4	9/16	3/8	1 3/8	N/A	3 1/4	4	7/16	4 3/4	4	5/8 - 11 UNC	6	7	BAB
2 1/2	2 1/2	4 5/8	6	1 3/4	4	1 1/4	9/16	3/8	2 1/16	N/A	3 1/4	4	7/16	5 1/2	4	5/8 - 11 UNC	8	9 3/4	BAB
3	3	5 1/8	6 1/4	1 3/4	4	1 1/4	9/16	3/8	2 9/16	N/A	3 1/4	4	7/16	6	4	5/8 - 11 UNC	9	10	BAB
4	4	6 3/8	7	2	4	1 1/4	5/8	7/16	3 5/8	N/A	3 1/4	4	7/16	7 1/2	8	5/8 - 11 UNC	11	16 3/4	BAC
5	5	7 3/8	7 1/2	2 1/8	4	1 1/4	3/4	1/2	4 3/4	N/A	3 1/4	4	7/16	8 1/2	8	3/4 - 10 UNC	15 1/2	22	BAD
6	5 3/4	8 1/2	8	2 1/8	4	1 1/4	3/4	1/2	5 1/2	N/A	3 1/4	4	7/16	9 1/2	8	3/4 - 10 UNC	17 1/2	24 1/4	BAD
8	7 3/4	10 11/16	9 1/2	2 1/2	6	1 1/4	7/8	5/8	7 1/2	N/A	5	4	9/16	11 3/4	8	3/4 - 10 UNC	30	42	CAE
10	9 3/4	13	10 3/4	2 1/2	6	2	1 1/8	N/A	9 19/32	1/4 x 1/4	5	4	9/16	14 1/4	12	7/8 - 9 UNC	45	65	CAF
12	11 3/4	14 13/16	12 1/4	3	6	2	1 1/8	N/A	11 9/16	1/4 x 1/4	5	4	9/16	17	12	7/8 - 9 UNC	78	108	CAF
14	13 23/64	16 7/8	12	3	6	3	1 3/8	N/A	13 1/8	5/16 x 5/16	5	4	9/16	18 3/4	12	1 - 8 UNC	105	143	CAG
16	15 3/8	19	12 15/16	4	6	3	1 5/8	N/A	15	3/8 x 3/8	5	4	9/16	21 1/4	16	1 - 8 UNC	180	238	CAH
18	17 3/8	21 3/8	14 1/2	4 1/4	8	4 1/4	1 7/8	N/A	17	1/2 x 3/8	6 1/2	4	13/16	22 3/4	16	1 1/8 - 7 UNC	222	261	DAJ
20	19 3/8	23 1/2	15 7/8	5	8	4 1/4	1 7/8	N/A	18 7/8	1/2 x 3/8	6 1/2	4	13/16	25	20	1 1/8 - 7 UNC	315	366	DAJ

Stainless steel body (inches)

Size	A	B	C	D	E	F	G	H(1)	Q(3)	Top Plate Drilling			Tapped Lug Data			Weight 990	(lbs.) 920	Adapt Code
										Bolt Circle	No. Holes	Hole Dia.	Bolt Circle	No. Holes	Tap Size			
1	1 3/16	2 3/8	3 1/8	1 1/8	2	4 3/4	3/8	1/4	4 5/8	1 3/4	4	5/16	N/A	N/A	N/A	1 1/4	N/A	AAA
1 1/2	1 3/4	3	3 3/4	1 3/16	2	3/4	3/8	1/4	1 7/16	1 3/4	4	5/16	N/A	N/A	N/A	1 3/4	N/A	AAA
2	2	3 7/8	5 1/2	1 5/8	3 1/16	1 1/4	9/16	3/8	1 3/8	3 1/4	4	7/16	4 3/4	4	5/8 - 11 UNC	3 3/4	5 1/4	BAB
3	3	5	6 1/4	1 3/4	3 1/16	1 1/4	9/16	3/8	2 9/16	3 1/4	4	7/16	6	4	5/8 - 11 UNC	6	7 1/4	BAB
4	4	6 1/4	7	2	3 1/16	1 1/4	5/8	7/16	3 5/8	3 1/4	4	7/16	7 1/2	8	5/8 - 11 UNC	8 1/2	13 1/2	BAC
6	5 3/4	8 1/4	8	2 1/8	3 1/16	1 1/4	3/4	1/2	5 1/2	3 1/4	4	7/16	9 1/2	8	3/4 - 10 UNC	13	19	BAD

Notes

1. H dimension refers to flat on stem.
2. 1-inch and 1 1/2-inch valve assemblies are furnished with integral 10-position throttling plate.
3. 'Q' dimension is the minimum allowable pipe or flange inside diameter at the centered body face to protect the disc sealing edge against damage when opening the valve.

Tyco Valves & Controls

www.tycovalves.com

Tyco Flow Control (TFC) provides the information herein in good faith but makes no representation as to its comprehensiveness or accuracy. This data sheet is intended only as a guide to TFC products and services. Individuals using this data sheet must exercise their independent judgment in evaluating product selection and determining product appropriateness for their particular purpose and system requirements. TFC MAKES NO REPRESENTATIONS OR WARRANTIES, EITHER EXPRESS OR IMPLIED, INCLUDING WITHOUT LIMITATION ANY WARRANTIES OF MERCHANTABILITY OR FITNESS FOR A PARTICULAR PURPOSE WITH RESPECT TO THE INFORMATION SET FORTH HEREIN OR THE PRODUCT(S) TO WHICH THE INFORMATION REFERS. ACCORDINGLY, TFC WILL NOT BE RESPONSIBLE FOR DAMAGES (OF ANY KIND OR NATURE, INCLUDING INCIDENTAL, INDIRECT, OR CONSEQUENTIAL DAMAGES) RESULTING FROM THE USE OF OR RELIANCE UPON THIS INFORMATION. Patents and Patents Pending in the U.S. and foreign countries. Tyco reserves the right to change product designs and specifications without notice.