

# KEYSTONE

## Spring Return and Double Acting Pneumatic Quarter-Turn Actuators For Output Torques to 27,624 lb.in.

### Features and benefits

- Compact rack and pinion design utilizes the whole piston area to develop output torque.
- Pistons with integral rack drive reduce the number of dynamic seals, minimizing air leakage.
- Double pistons nullify sideloads on the pinion shaft, minimizing bearing wear and extending life.
- Internal air porting eliminates external tubing.
- Hard anodized aluminum body with external electrostatic powder coating (ESPC) finish protects against corrosive environments.
- Female output drive enables direct mounting of most Keystone valves, eliminating special adaptation connections and assuring correct alignment.
- Bottom entry pinion shaft simplifies assembly and provides anti-blowout feature.
- Anti-friction piston pads ensure no metal-to-metal contact, providing smooth operation. Ideal for modulating or on/off control applications.
- Adjustable travel stops standard in both directions on sizes 065 through 181.
- An extensive range of standard accessories are available for direct mounting.
  - Solenoid valves
  - Limit switchboxes
  - Positioners
  - Dec clutchable manual override gearbox
  - High visibility indicator



### General applications

For remote control of any quarter-turn application; for example, ball, butterfly or rotary plug valves, dampers, etc.

### Technical data

Max. Supply Pressure	: 150 psig
Rated Supply Pressure	: 120 psig
Double Acting Torque	: 27,624 lb.in. @ 120 psig
Spring End Torque	: 10,155 lb.in. @ 100 psig
Temperature Range	: -4°F to 200°F [-20°C to 90°C]
Optional Temperature Ranges Available	: -15°F to 300°F [-26°C to 150°C] -40°F to 160°F [-40°C to 71°C]

**tyco** / Flow Control

Total Flow Control Solutions™

Keystone is either a trademark or registered trademark of Tyco International Services AG or its affiliates in the United States and/or other countries. All other brand names, product names, or trademarks belong to their respective holders.

**Double Acting Pneumatic Quarter-Turn Actuator**

**Spring Return Pneumatic Quarter-Turn Actuator**

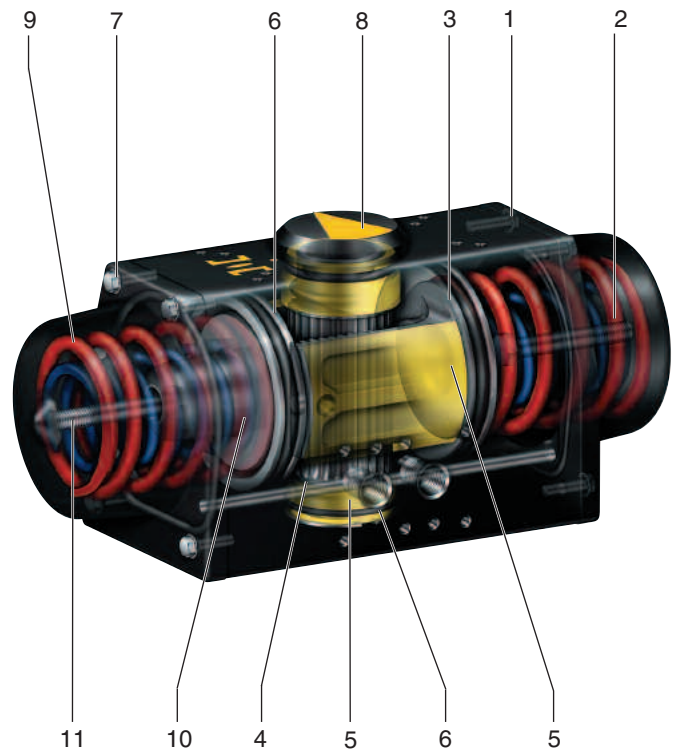
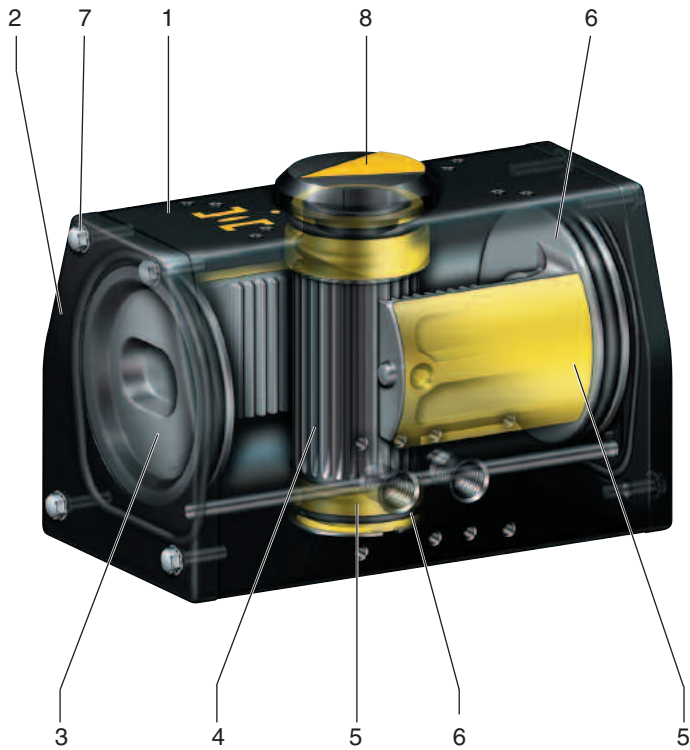

**Materials of Construction**

Part	Material	US Material Standard	UK Material Standard	DIN Material Standard
1 Body	Extruded aluminum (hard anodized and ESPC*)	ASTM B221	BS1474 6063	DIN 3.33206.51
2 End cap	Die-cast aluminum LM6 or LM24 (ESPC*)	ASTM B85	BS1490	DIN 1725 - 230 or 226
3 Piston (003 only) Piston (006-181)	Glass filled nylon 66 Die-cast aluminum (anodized) LM6 or LM24	ASTM B85	BS1490	DIN 1725 - 230 or 226
4 Pinion shaft	Carbon steel (sealbond - N coated)	ASTM A108	BS970 080M40	C40
5 Bearings	Engineered polymer			
6 O-rings	Nitrile			
7 Fasteners	304 stainless steel	ASTM A193	BS970 Part 3 - 304/305	DIN 267 Part 3
8 Indicator	ABS			
9 Spring	Spring steel (ESPC*)	ASTM A401	BS5216 HS3	DIN 17223 Pti
10 Spring Cone	Die-cast aluminum LM6	ASTM B85	BS1490	DIN 1725
11 Spring retaining bolt	Steel (plated)	ASTM A193	BS970 Part 3 - 304/305	DIN 267 Part 3

\* electrostatic powder coating

### Notes

- Operating times under no load for air pressures from 40 psig to 100 psig. (Times based on actual measurements.)
- Total time is defined as time required from switching solenoid valve to completion of 90 degree stroke.
- Stroke times can be increased or decreased dramatically by using speed controls, oversized pilot valves or quick-exhaust valves.
- Air Consumption:  
Cubic inches shown in chart represent actual free air volume in either open or close direction. Air consumption will vary depending on supply pressure. To determine standard cubic feet per minute use the following formula:

Double Acting SCFM =

$$\left( \frac{\text{Open} + \text{Close Vol. in}^3}{1728} \right) \left( \frac{\text{Supply Air psig} + 14.7}{14.7} \right) \left( \text{Cycles/Min} \right)$$

Spring Return SCFM =

$$\left( \text{Air Stroke Vol. in}^3 \right) \left( \frac{\text{Supply Air psig} + 14.7}{14.7} \right) \left( \text{Cycles/Min} \right)$$

Example: Calculate SCFM for size 036 double acting using 80 psig air supply and 5 cycles/minute.

Double Acting SCFM =

$$\left( \frac{119 + 83}{1728} \right) \left( \frac{80 + 14.7}{14.7} \right) (5) \text{ SCFM} = 3.77$$

- All Double Acting Actuator operating times are based on using a standard Tyco 5/2 solenoid valve with nominal  $.7C_v$ .
- All Spring Return Actuator operating times are based on using a standard Tyco 3/2 solenoid valve with nominal  $.4C_v$ .

### Double Acting Actuator Operating Times (seconds)

Actuator Size	Stroke Time	Total Time
003	0.16	0.24
006	0.26	0.37
012	0.45	0.64
024	0.90	1.22
036	1.32	1.76
065/066	3.60	5.10
090/091	4.50	6.30
180/181	5.90	7.90

### Spring Return Actuator Operating Times (seconds)

Actuator Size	Stroke Time		Total Time	
	Air	Spring	Air	Spring
003S	0.30	0.35	0.40	0.42
006S	0.50	0.50	0.52	0.54
012S	0.63	0.68	1.00	1.10
024S	1.40	1.60	2.10	2.30
036S	2.10	2.20	2.60	2.90
065S/066S	3.60	4.50	4.80	5.80
090S/091S	8.70	5.20	9.50	6.30
180S/181S	12.60	10.75	12.90	11.20

### Actuator Piston Displacement (in<sup>3</sup>)

Actuator Size	Open-Double Acting		Close - Double Acting
	Air Stroke	Spring Return	
003	11		8
006	21		14
012	38		28
024	79		56
036	119		83
065/066	215		161
090/091	292		204
180/181	591		409

### Actuator Weight (lb.)

Actuator Size	Double Acting	Spring Return
003	2.7	3.3
006	5.7	7.9
012	7.7	12.5
024	16.7	26.0
036	27.0	38.0
065/066	41.9	75.0
090/091	63.9	99.2
180/181	99.2	158.7

# Keystone 79U Pneumatic Actuator

## Size 003

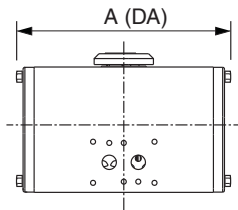
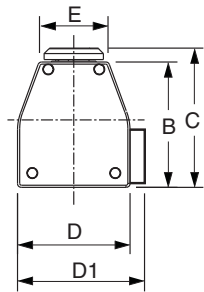
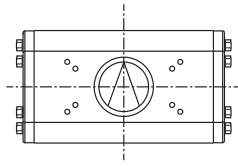

## Size 003S

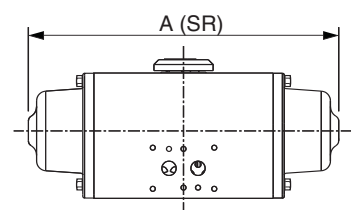
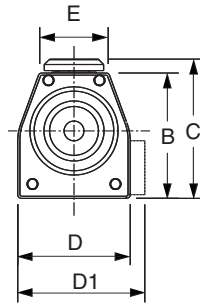
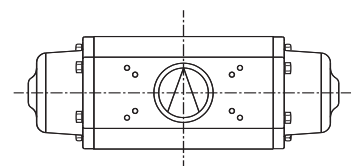

## Size 006-036

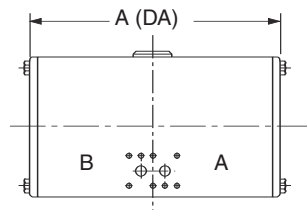
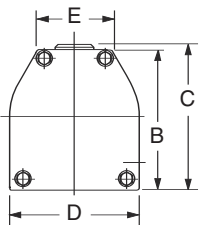
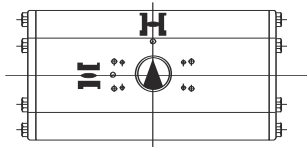

## Size 006S-036S

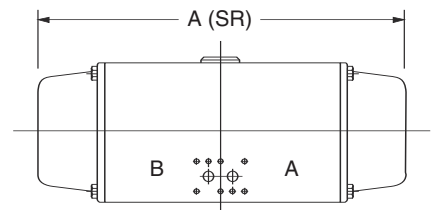
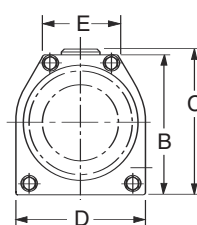
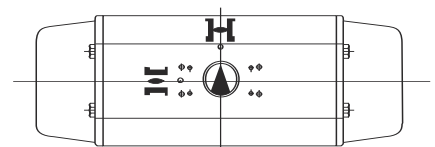

## Size 065-181

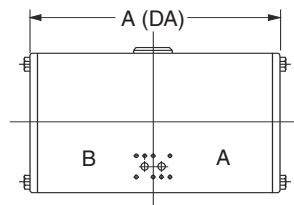
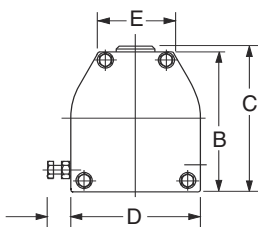
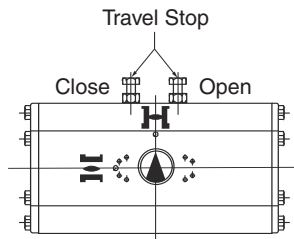

## Size 065S-181S

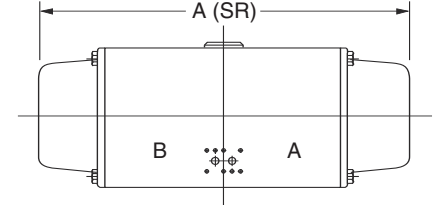
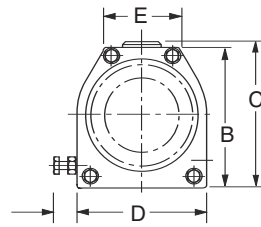
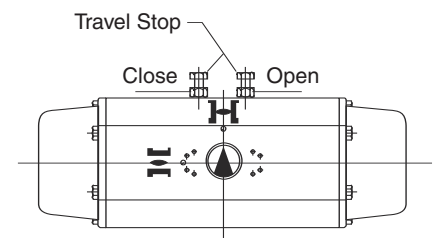

1.38 Max.  
recommended

1.38 Max.  
recommended

### General Information

- A. A comprehensive range of adaptors are available to suit all Tyco valve stems.
- B. Actuators can be mounted parallel or perpendicular to valve flow.

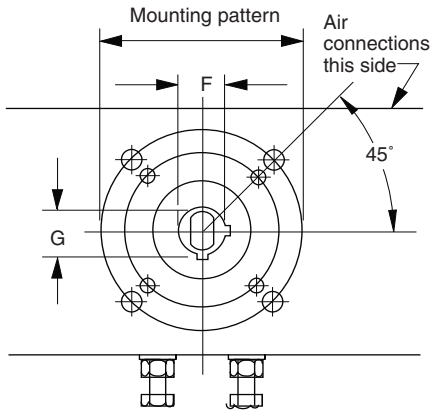

### Notes

Each body has both types of accessory mounting pads.

1. Tyco standard mounting pad
2. NAMUR mounting pad

### Sizes 065 to 181

1. On sizes 065 to 181, the total travel of 100 degrees allows for end-of-travel adjustment of 5 degrees over and 7 degrees under at both open and close positions.
2. Travel stop bolts (when present) must not be used for manual override.
3. Mounting pattern with 5.00 PCD is only available on 180/181 size with the use of a 0.75 thick mounting plate.

### Actuator Dimensions (inches)

Actuator Size	A(SR)	A(DA)	B	C	D	D1	E
003	8.23	5.57	3.19	3.54	3.27	3.58	2.20
006	10.10	6.55	4.08	4.41	3.66	—	2.26
012	11.10	7.13	5.00	5.35	4.38	—	3.25
024	13.82	9.17	5.90	6.26	5.35	—	3.35
036	16.69	10.72	6.87	7.24	6.00	—	3.50
065/066	19.69	12.78	8.55	8.90	8.00	—	4.50
090/091	23.00	16.08	8.55	8.90	8.00	—	4.50
180/181	27.32	18.94	10.55	10.90	9.84	—	5.12

### Mounting Dimensions (inches) - 79U

Actuator Size	Shaft Bore F	Keyway Size		Key Size	Mounting Patterns	
		G	Width		PCD	Mounting Holes
003	0.814 Dia.	0.855	0.189	3/16 Sq.	1.75	4 x 1/4-20UNC x 0.38 Dp.
006/012	1.004 Dia.	1.060	0.252	1/4 x 3/16	3.25	4 x 3/8-16UNC x 0.56 Dp.
024/036	1.128 Dia.	1.250	0.252	1/4 Sq.	3.25 5.00	4 x 3/8-16UNC x 0.56 Dp. 4 x 1/2-13UNC x 0.63 Dp.
065	1.128 Dia.	1.250	0.252	1/4 Sq.	5.00	4 x 1/2-13UNC x 0.63 Dp.
066	1.380 Dia.	1.523	0.315	5/16 Sq.	5.00	4 x 1/2-13UNC x 0.63 Dp.
090	1.628 Dia.	1.808	0.378	3/8 Sq.	5.00	4 x 1/2-13UNC x 0.63 Dp.
091	1.882 Dia.	2.058	0.504	1/2 x 3/8	6.50	4 x 3/4-10UNC x 1.00 Dp.
180	1.882 Dia.	2.058	0.504	1/2 x 3/8	5.00 6.50	4 x 1/2-13UNC x 0.63 Dp. <sup>3</sup> 4 x 3/4-10UNC x 1.00 Dp.
181	2.257 Dia.	2.437	0.504	1/2 x 3/8	5.00 6.50	4 x 1/2-13UNC x 0.63 Dp. <sup>3</sup> 4 x 3/4-10UNC x 1.00 Dp.

### Accessory Drillings to Actuator Body (inches)

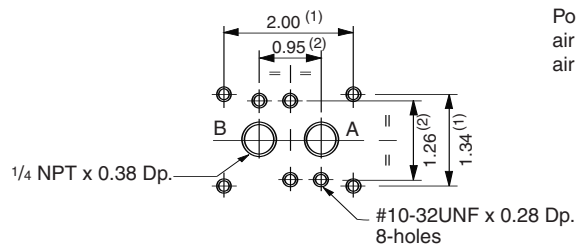

Port Hole Drillings  
air port 'B' - CLOSED  
air port 'A' - OPEN

\* On sizes 180/181 drillings are aligned vertically (not horizontally as shown) with Port A at top.

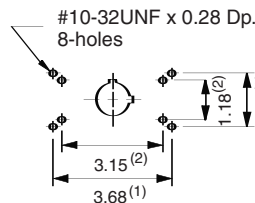

Top mounting drilling  
sizes 003 to 036

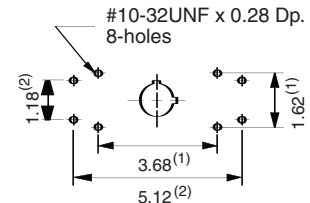

Top mounting drilling  
sizes 065 to 181

### Actuator Shaft Top Detail (inches)

Size	Shaft Bore
003	0.814 Dia. x 0.855 x 0.189 Keyway (3/16 Sq. Key)
006/012	1.004 Dia. x 1.060 x 0.252 Keyway (1/4 x 3/16 Key)
024/036/065/066/090/091/180/181	1.128 Dia. x 1.250 x 0.252 Keyway (1/4 Sq. Key)

**Output Torques (lb.in.) for Single Acting (spring return) Actuators**

Actuator Size	Spring Rating (psig)	Spring End	Spring Start	Air Torque	Air Supply in psig					
					40	50	60	80	100	120
003S	40	62	104	Start	81	123	165	250	334	418
				End	39	81	123	208	292	376
	60	100	162	Start			127	212	296	380
				End			65	150	234	318
80	137	221	Start				175	259	343	
			End				91	175	259	
100	174	279	Start					222	306	
			End					117	201	
006S	40	123	200	Start	151	232	312	474	635	796
				End	74	155	235	397	558	719
	60	197	312	Start			238	400	561	722
				End			123	285	446	607
80	272	425	Start				325	486	647	
			End				172	333	494	
100	346	538	Start					412	573	
			End					220	381	
012S	40	245	395	Start	288	445	601	915	1228	1542
				End	138	295	451	765	1078	1392
	60	391	616	Start			455	769	1082	1396
				End			230	544	857	1171
80	536	836	Start				624	937	1251	
			End				324	637	951	
100	709	1058	Start					764	1078	
			End					415	729	
024S	40	482	783	Start	583	896	1209	1835	2462	3088
				End	282	595	908	1534	2161	2787
	60	771	1221	Start			920	1546	2173	2799
				End			470	1096	1723	2349
80	1059	1660	Start				1258	1885	2511	
			End				657	1284	1910	
100	1347	2098	Start					1597	2223	
			End					846	1472	
036S	40	718	1149	Start	874	1342	1810	2746	3882	4618
				End	443	911	1379	2315	3251	4187
	60	1149	1794	Start			1379	2315	3251	4187
				End			734	1670	2606	3542
80	1579	2438	Start				1885	2821	3757	
			End				1026	1962	2898	
100	2006	3083	Start					2392	3328	
			End					1317	2253	
065S/066S	40	1395	2896	Start	1681	2586	3491	5300	7109	8919
				End	813	1718	2623	4432	6241	8051
	60	2226	3530	Start			2660	4469	6278	8088
				End			1356	3165	4974	6784
80	3059	4578	Start				3636	5445	7255	
			End				2117	3926	5736	
100	3892	6064	Start					4612	6422	
			End					2440	4250	
090S/091S	40	1772	2874	Start	2135	3284	4433	6731	9029	—
				End	1033	2182	3331	5629	7927	—
	60	2827	4484	Start			3378	5676	7974	—
				End			1721	4019	6317	8615
80	3885	6093	Start				4618	6916	9214	
			End				2410	4708	7006	
100	4943	7703	Start					5858	8156	
			End					3098	5396	
180S/181S	40	3637	5905	Start	4389	6750	9111	13833	18554	23276
				End	2122	4482	6843	11565	16286	21008
	60	5810	9212	Start			6938	11660	16381	21103
				End			3537	8258	12980	17701
80	7983	12518	Start				9487	14209	18930	
			End				4952	9673	14395	
100	10155	15825	Start					12036	16758	
			End					6367	11008	



**Output Torques (lb.in.) for Double Acting (air-to-air) Actuators**

Actuator Size	Air Supply in psig					
	40	50	60	80	100	120
003	156	198	240	325	409	493
006	298	379	459	621	782	943
012	580	737	893	1207	1520	1834
024	1159	1472	1785	2411	3038	3664
036	1732	2200	2668	3604	4540	5476
065/066	3347	4252	5157	6966	8775	10585
090/091	4252	5401	6550	8848	11146	13444
180/181	8736	11097	13458	18180	22902	27624

**Control Accessories**

**Solenoid Valves**

A comprehensive range of solenoid valves is available for controlling the pneumatic supply to the actuator cylinder by means of an electrical signal. Alternative specifications of solenoid valves include:

- Weatherproof to NEMA 4, 4X
- Explosion-proof to NEMA 4, 4X, 7, 9
- Intrinsically safe to Class 1, A, -D, Class 2 E-G, Div.1&2



**AVID Position Monitors**

The AVID range of position monitoring equipment incorporates HiVue™ Local Visual Display, EasiFix™ Switch adjustment and ModMount™ Assembly facilities, enabling direct, low profile mounting.

**K-Switch™**

Quarter Turn position indicator, UL & CUL approved to NEMA 4, 4X, 7 and 9 for use in Class1, Div 1, Group C&D and Class II, Div 1, Groups E, F & G Hazardous Locations.

**XA**

FM & CSA approved to NEMA 4, 4X, 7, 9 position monitor for use in Class1, Div 1, Group C&D and Class II, Div 1, Groups E, F & G Hazardous Locations.

**ZR**

NEMA/FM approved position monitor for General Purpose and Intrinsically Safe applications

**ZR Plus**

Integrated monitoring and control of automated valves in a single, NEMA/FM approved package for General Purpose and Intrinsically Safe applications.

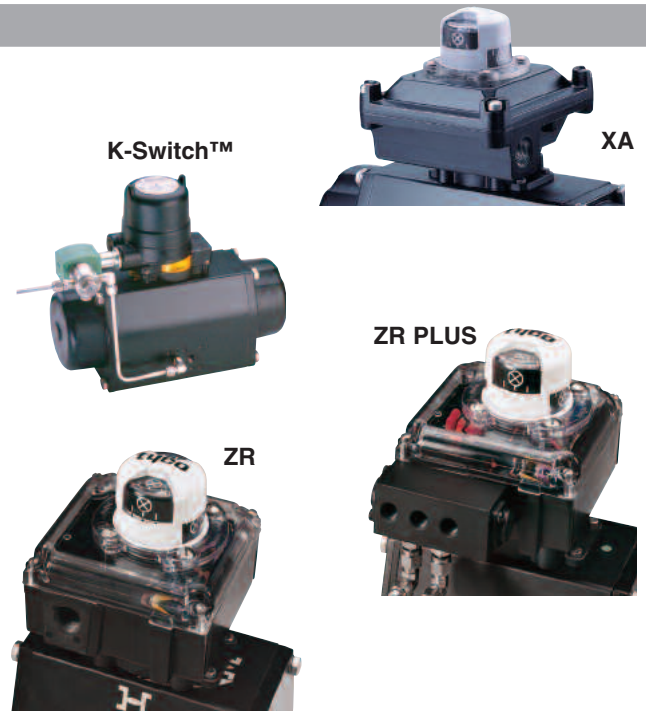

## Control Accessories (continued)

### AVID Positioners

The AVID range of Analogue and Smart Positioners offers solutions to the precise positioning of pneumatic actuators and are mounted directly to the 79U actuator housing, saving height and cost. Positioners may also be used for mounting to NAMUR (VDI/VDE 3845) standards if required.

#### MCal

Analogue Positioner for 3 to 15 psi or 4 to 20 mA signals. Available for use in 4, 4X, 7, and 9 areas.

#### EaziCal™ IR

Analogue Positioner with AutoCal™ calibration certified General Purpose. Weatherproof NEMA 4, 4X.

#### SmartCal™

A NEMA/FM approved Intelligent Positioner, Weatherproof NEMA 4, 4X, allowing for AutoCal™ keypad calibration, HART® communications capability and on-site diagnostic information.



MCal

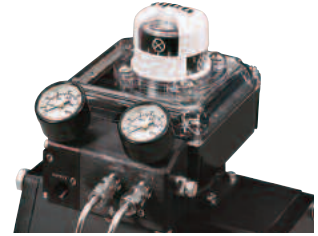

EaziCal™ IR



SmartCal™

### Network Solutions

The AVID range of PlantNet Monitors facilitates communication with AS-interface®, DeviceNet™, Foundation™ fieldbus and PROFIBUS Network Protocols to enable complete system integration of all valve units.



### Notes

1. AS-interface® is a registered trademark of AS-International.
2. DeviceNet™ is a trademark of ODVA.
3. Foundation™ fieldbus is a registered trademark of the Fieldbus Foundation.
4. HART® is a registered trademark of the HART Communication Foundation.
5. PROFIBUS® is a registered trademark of PROFIBUS International.
6. EaziCal™, SmartCal™, HiVue™, EasiFix™, K-Switch™ and ModMount™ are either trademarks or registered trademarks of Tyco International Services AG or its affiliates in the United States and/or other countries. All other brand names, product names, or trademarks belong to their respective holders.

**Tyco Valves & Controls**

[www.tycoflowcontrol.com](http://www.tycoflowcontrol.com)

Tyco Flow Control (TFC) provides the information herein in good faith but makes no representation as to its comprehensiveness or accuracy. This data sheet is intended only as a guide to TFC products and services. Individuals using this data sheet must exercise their independent judgment in evaluating product selection and determining product appropriateness for their particular purpose and system requirements. TFC MAKES NO REPRESENTATIONS OR WARRANTIES, EITHER EXPRESS OR IMPLIED, INCLUDING WITHOUT LIMITATION ANY WARRANTIES OF MERCHANTABILITY OR FITNESS FOR A PARTICULAR PURPOSE WITH RESPECT TO THE INFORMATION SET FORTH HEREIN OR THE PRODUCT(S) TO WHICH THE INFORMATION REFERS. ACCORDINGLY, TFC WILL NOT BE RESPONSIBLE FOR DAMAGES (OF ANY KIND OR NATURE, INCLUDING INCIDENTAL, INDIRECT, OR CONSEQUENTIAL DAMAGES) RESULTING FROM THE USE OF OR RELIANCE UPON THIS INFORMATION. Patents and Patents Pending in the U.S. and foreign countries. Tyco reserves the right to change product designs and specifications without notice.